



PRODUCT CATALOGUE



OVER 25 YEARS OF SUCCESS

www.hpeprocess.com

RJT union parts to BS4825 part 5	6
RJT union parts dimensions.....	7
DIN 11851 parts for metric OD tube	8
DIN union parts for Metric OD tube features and advantages	9
DIN metric OD union parts dimensions.....	9
DIN 11851 parts for Imperial OD tube.....	10
DIN union parts for Imperial OD tube	10
DIN Imperial OD union parts dimensions	11
IDF fittings.....	12
IDF fittings dimensions	13
SMS Fittings	14
SMS fittings features and advantages	15
SMS fittings dimensions	15
SMS Aseptic fittings	16
SMS Aseptic fittings features and advantages	17
SMS Aseptic fittings dimensions.....	17
Versaline clamp fittings	18
Versaline clamp fittings dimensions.....	19
Stainless steel bends to BS4825	20
Stainless steel bends to BS4825 dimensions.....	20
Hand welding bends, 1D and 2D bends.....	21
Bends for jacketing	23
Equal and Pulled Tees.....	25
Equal and Pulled Tees dimensions	26
Stainless steel reducing tees.....	27
Stainless steel reducing tees features and benefits	28
Versaline Grade 304L and 316L Stainless steel tube	29
Versaline stainless steel tubing features and advantages.....	30
Concentric and Eccentric reducers	31
Versaline stainless steel Butterfly Valves	32
Versaline Butterfly Valve handle options	35
Versaline Butterfly Valve technical data.....	36
Versaline control head.....	38
Versaline control head mounting instructions.....	39
Versaline 2 Piece stainless steel BSP female ball valve	40
Versaline 2 Piece BSP female ball valve features and advantages.....	41
Versaline 3 piece stainless steel ball valve	42

HpE Process Product Catalogue	
Versaline 3 piece ball valve features and advantages.....	43
Versaline 3 piece ball valve technical data.....	44
Versaline 3 way ball valve.....	45
Versaline 3 way ball valve technical data.....	46
Versaline ball valve actuator.....	47
PCD and thread size of actuator mounting holes.....	48
Versaline ball valve actuator shaft adaptor.....	48
Non return valve.....	49
Regulating Valve.....	51
90 Degree (angle pattern) strainer.....	52
Y Strainers, In-line filter and Duplex Strainers.....	52
180 Degree strainer.....	54
Versaline pressure relief valve (VPRP Type).....	55
PEMS IV Sample Valve.....	56
PEMS simplified sampling valve with membrane.....	57
Aseptic Sampling Valves.....	59
ND06 Design.....	61
ND10 and ND15 Design.....	63
Aseptic sampling valve REM.....	65
Evoguard Aseptic Sampling Valve.....	66
Evoguard Range Sampling System.....	67
Safety Valve.....	68
BOGV Pressure & Vacuum safety valve.....	69
BOG Pressure, Vacuum-relief & gas collection safety valve.....	70
HSV-A Pressure, Vacuum-relief & thermal shock safety valve 3-A.....	74
Evoguard Overflow Valve.....	77
Static spray ball.....	78
Static spray ball selection chart.....	79
RSB type rotating sprayball.....	80
Versaline 360 Rotary Head Jet.....	83
SGT Type weld in Sightglass DIN 8902.....	87
SGT Type Sightglass self-draining design neck ring design comparison.....	88
Versaline Sightglass DIN28120.....	89
Versaline PVC Hose.....	91
Adjustable feet.....	93
Adjustable Feet – EHEDG & 3A.....	95
Pumps.....	97
Centrifugal pumps.....	97

HpE Process Product Catalogue	
Positive displacement pumps.....	97
Dosing and Metering	97
Piston Pumps	97
Drum unloader pump systems	97
Rotary Lobe Pumps.....	98
Twinscrew Pumps.....	98
Progressive Cavity.....	98
Peristaltic Pump.....	98
Liquid Ring	99
Homogenisers.....	100
Manways.....	101
Mixers	102
Vertical agitator – Tandem	102
Lateral agitators: Food Industry	104
IBC vertical agitator	108
Tank Vents	110
Vent/20/56	110
Vent /A50B	111
Evoguard Pumps, valves & tank safety equipment	112
Evoguard Pumps.....	112
Evoguard Valves.....	123
Butterfly valves	123
Range seat valve	125
Range Double Seal Valve	127
Range Mixproof valve.....	129
Range Control Valve	133
Range E(extended) S(shelf) L(life) Seat Valve.....	135
Range E(extended) S(shelf) L(life) Mixproof Valve	137
Range Aseptic Seat Valve.....	139
Range Aseptic Double Seat Valve	141
Range Vacuum Valve	143
Range Safety Valve	145
Control module.....	146
Valve blocks	147
Evoguard tank safety and cleaning systems.....	149

RJT union parts to BS4825 part 5



The RJT union (Ring Joint Type) was the original hygienic fitting used in the UK. It can be recognised by the slim hexagon nut and the O section joint ring.

Although still widely used because of comparative costs, it is not considered suitable for modern systems which are cleaned in place, because the crevice between the liner and the spigot on the male is difficult to clean.

However, the positive location of the joint ring in the male part and the coarse whitworth thread make a common choice where regular dismantling takes place for cleaning.

RJT union parts conforms to BS4825 part 5 (formerly B.S 1864).

The standard joint rings are supplied in Nitrile material. They are also available in EPDM, SILICON, PTFE & VITRON.

SIZE	NUT	MALE	LINER	JOINT RING	FULL UNION	PRESSURE RATING
1"	RN10	RM10	RL10	RJ10	RU10	10 BAR
1.5"	RN15	RM15	RL15	RJ15	RU15	10 BAR
2"	RN20	RM20	RL20	RJ20	RU20	10 BAR
2.5"	RN25	RM25	RL25	RJ25	RU25	10 BAR
3"	RN30	RM30	RL30	RJ30	RU30	10 BAR
4"	RN40	RM40	RL40	RJ40	RU40	10 BAR

RJT union parts features and benefits



- RJT union parts.
- All Versaline union parts are fully traceable.
- Excellent availability, EX STOCK.
- RJT union parts are manufactured to B.S. 4825 Part 5.

RJT union parts dimensions

Special fabrications can be manufactured to order

Nominal dimensions - union parts - mm

Size	A	B	D
1"	21.5	4.8	45.7
1.1/2"	21.5	4.8	58.4
2"	21.5	4.8	72.7
2.1/2"	21.5	4.8	85.4
3"	21.5	4.8	98.1
4"	21.5	4.8	123.5

Size	A	B
1"	22.2	50.8
1.1/2"	22.2	65.0
2"	22.2	79.4
2.1/2"	22.2	92.1
3"	22.2	104.8
4"	22.2	130.2

Size	A	B	D
1"	12	2.5	41.3
1.1/2"	12	2.5	54.0
2"	12	2.5	66.7
2.1/2"	12	2.5	79.4
3"	12	2.5	92.1
4"	22	2.5	117.8

Size	A	D
1"	6.6	39.9
1.1/2"	6.6	52.6
2"	6.6	65.3
2.1/2"	6.6	78.0
3"	6.6	90.7
4"	6.6	116.1

DIN 11851 parts for metric OD tube



SIZE	NUT	MALE	LINER	JOINT RING	FULL UNION	PRESSURE RATING
NW10	DN10	DM10L	DL10L	DJ10	DU10	40 BAR
NW15	DN15	DM15L	DL15L	DJ15	DU15	40 BAR
NW20	DN20	DM20L	DL20L	DJ20	DU20	40 BAR
NW25	DN25	DM25L	DL25L	DJ25	DU25	40 BAR
NW32	DN32	DM32L	DL32L	DJ32	DU32	40 BAR
NW40	DN40	DM40L	DL40L	DJ40	DU40	40 BAR
NW50	DN50	DM50L	DL50L	DJ50	DU50	25 BAR
NW65	DN65	DM65L	DL65L	DJ65	DU65	25 BAR
NW80	DN80	DM80L	DL80L	DJ80	DU80	25 BAR
NW100	DN100	DM100L	DL100L	DJ100	DU100	25 BAR
NW125	DN125	DM125L	DL125L	DJ125	DU125	25 BAR
NW150	DN150	DM150L	DL150L	DJ150	DU150	25 BAR

The DIN 11851 Union is the German standard hygienic fitting. It is recognised by the round slotted nut, D section joint ring and the coned recess in the male part.

DIN Union parts are manufactured to suit both DIN imperial and DIN metric OD tube.

The Din Union is the most robust hygienic union on the market. A crevice always exists between the faces of the male part and liner which cannot be properly cleaned in place.

DIN 11851 fittings can be supplied with EHEDG approved aseptic inserts to replace the standard seals.

We can also supply DIN aseptic fittings to DIN11853 and DIN11864.

DIN union parts for metric OD tube features & advantages

- DIN metric union parts
- All Versaline union parts are fully traceable
- Excellent availability, EX STOCK
- DIN Union parts are manufactured to DIN11851

DIN metric OD union parts dimensions

Special fabrications can be manufactured to order

Nominal dimensions - union parts - mm

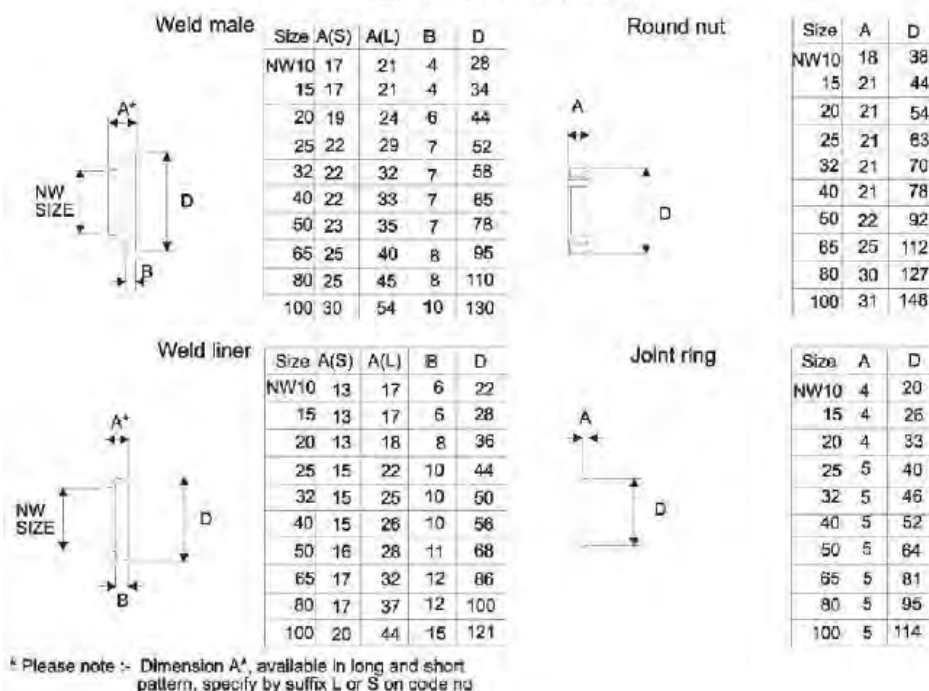

DIN 11851 parts for imperial OD tube



SIZE	NUT	MALE	LINER	JOINT RING	FULL UNION	PRESSURE RATING
1"	DN25	DMi10L	DLi10L	DJ25	DUi10	40 BAR
1.5"	DN40	DMi15L	DLi15L	DJ40	DUi15	40 BAR
2"	DN50	DMi20L	DLi20L	DJ50	DUi20	25 BAR
2.5"	DN65	DMi25L	DLi25L	DJ65	Dui25	25 BAR
3"	DN80	DMi30L	DLi30L	DJ80	DUi30	25 BAR
4"	DN100	DMi40L	DLi40L	DJ100	Dui40	25 BAR

DIN union parts for imperial OD tube

The DIN 11851 union is the German standard hygienic fitting. It is recognised by the round slotted nut, D section joint ring and the coned recess in the male part.

DIN union parts are manufactured to suit both DIN imperial, OD tube and DIN metric OD tube. The DIN union is the most robust hygienic union on the market.

A crevice always exists between the faces of the male part and liner which cannot be properly cleaned in place.

DIN union parts for imperial OD tube features & advantages



- DIN Union parts for Imperial OD tube
- All Versaline union parts are fully traceable
- Excellent availability, usually EX STOCK
- DIN Union parts are manufactured to DIN 11851

DIN imperial OD union parts dimensions

Nominal dimensions - union parts - mm

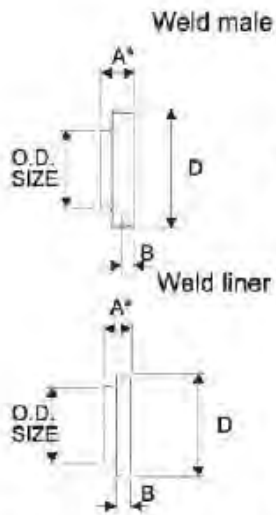

Size	A(S)	A(L)	B	D
1"	22	29	7	52
1.1/2"	22	33	7	65
2"	22	35	7	78
2.1/2"	25	40	8	95
3"	30	45	8	110
4"	30	54	10	130

Size	A(S)	A(L)	B	D
1"	18	22	10	44
1.1/2"	18	26	10	56
2"	20	28	11	68
2.1/2"	20	32	12	86
3"	20	37	12	100
4"	23	44	15	121

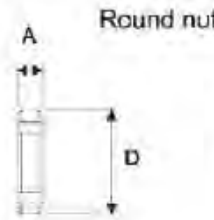

Size	A	D
1"	21	63
1.1/2"	21	78
2"	21	92
2.1/2"	25	112
3"	30	127
4"	31	148

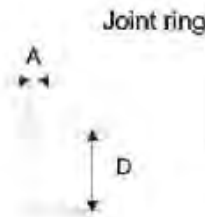

Size	A	D
1"	5	40
1.1/2"	5	52
2"	5	64
2.1/2"	5	81
3"	5	95
4"	5	114

* Please note :- Dimension A*, available in long and short pattern, specify by suffix L or S on code no.

IDF fittings



IDF (International Dairy Federation) sometimes referred to as ISS. (International sanitary standard) was introduced in the sixties as the successor to RJT because of its crevice free assembly. It can be recognised by the wide hexagon nut and T - section joint ring. The joint ring locates on both liner and male part but does not tend to stay in place when the union is disassembled and can prove awkward.

In cases where the Union is dismantled frequently, the use of the L section joint ring will alleviate the problem as the joint ring will locate on one half. IDF union parts conform to BS4825 part 4

SIZE	NUT	MALE	LINER	JOINT RING	FULL UNION	PRESSURE RATING
1"	IN10	IM10	IL10	IJ10	IU10	16 BAR
1.5"	IN15	IM15	IL15	IJ15	IU15	16 BAR
2"	IN20	IM20	IL20	IJ20	IU20	16 BAR
2.5"	IN25	IM25	IL25	IJ25	IU25	16 BAR
3"	IN30	IM30	IL30	IJ30	IU30	16 BAR
4"	IN40	IM40	IL40	IJ40	IU40	16 BAR

The standard joint ring material supplied is Nitrile. Other material types available are EPDM, SILICON, PTFE, and VITON.

IDF fittings features and benefits



- IDF union parts
- All Versaline union parts are fully traceable.
- Excellent availability. Ex Stock.
- Conform to BS4825 part 4.

IDF fittings dimensions

Nominal dimensions - union parts - mm

Weld male

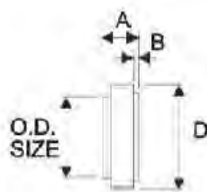

Size	A	B	D
1"	21.5	3	37.1
1.1/2"	21.5	3	50.7
2"	21.5	3	64.2
2.1/2"	21.5	3	77.7
3"	21.5	3	91.2
4"	30.0	3.2	125.9

Hex nut

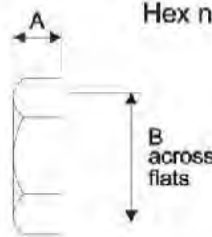

Size	A	B
1"	30	46.0
1.1/2"	30	60.0
2"	30	75.0
2.1/2"	30	90.0
3"	30	105.0
4"	35	133.0

Weld liner

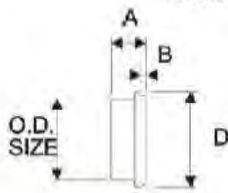

Size	A	B	D
1"	21.5	3	33.8
1.1/2"	21.5	3	47.0
2"	21.5	3	60.5
2.1/2"	21.5	3	74.0
3"	21.5	3	87.5
4"	30.0	3	120.6

Joint ring T section

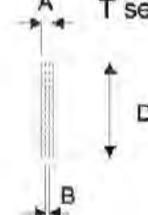

Size	A	B	D
1"	7.0	3	32.5
1.1/2"	7.0	3	46.0
2"	7.0	3	59.5
2.1/2"	7.0	3	73.2
3"	7.0	3	86.5
4"	9.5	5	119.0

SMS fittings



The SMS union is the Swedish standard hygienic fitting. It can be recognised by the round slotted nut and square section joint ring. Probably the most widely used hygienic fitting worldwide. There is always a small crevice between the face of the male spigot and the liner which makes CIP questionable. The use of the L section joint rings with the standard union parts should be avoided as the male spigot can cut the lip on the joint ring causing subsequent product contamination. Where a true crevice free assembly is required, the SMS ASEPTIC union should be used.

SIZE	NUT	MALE	LINER	JOINT RING	FULL UNION	PRESSURE RATING
1"	SN10	SM10	SL10	SJ10	SU10	10 BAR
1.5"	SN15	SM15	SL15	SJ15	SU15	10 BAR
2"	SN20	SM20	SL20	SJ20	SU20	10 BAR
2.5"	SN25	SM25	SL25	SJ25	SU25	10 BAR
3"	SN30	SM30	SL30	SJ30	SU30	10 BAR
4"	SN40	SM40	SL40	SJ30	SU40	10 BAR

The standard joint rings are supplied in Nitrile Material. They are also available in EPDM, SILICON, PTFE, and VITON.

SMS fittings features and advantages



- SMS union parts.
- All Versaline union parts are fully traceable.
- Excellent availability. Ex Stock.

SMS fittings dimensions

Nominal dimensions - union parts - mm

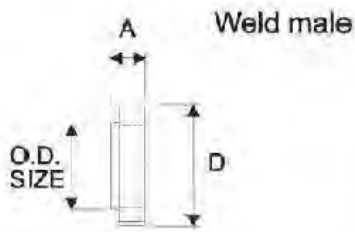

Size	A	D
1"	15.0	40.0
1.1/2"	20.0	60.0
2"	20.0	70.0
2.1/2"	24.0	85.0
3"	24.0	98.0
4"	35.0	132.0

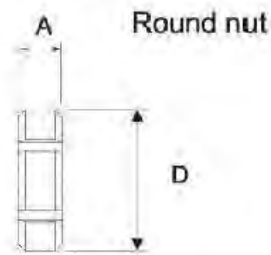

Size	A	D
1"	20.0	51.0
1.1/2"	25.0	74.0
2"	26.0	84.0
2.1/2"	30.0	100.0
3"	32.0	114.0
4"	30.0	150.0

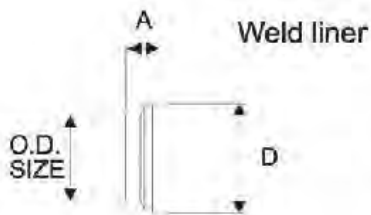

Size	A	D
1"	16	35.5
1.1/2"	16	55.0
2"	17	65.0
2.1/2"	17	80.0
3"	19	93.0
4"	19	127.0

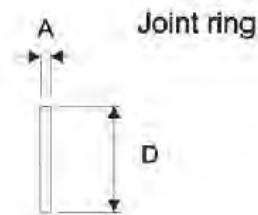

Size	A	D
1"	5.5	32.0
1.1/2"	5.5	48.0
2"	5.5	61.0
2.1/2"	5.5	73.5
3"	5.5	86.0
4"	5.5	114.0

SMS aseptic fittings



The SMS Aseptic union is a modified version of the SMS standard union, designed to accept an L section joint ring and give a true crevice free bore. On assembly, the nut is tightened until metal to metal contact is made between the outer rim of the liner and male part. This gives a pre-set compression on the seal, eliminating the possibility of overtightening and prolonging joint life. The liners are of the long type with a shoulder which is dimensioned and tolerance to locate inside the nut to give perfect concentric alignment on assembly.

SIZE	NUT	MALE	LINER	JOINT RING	FULL UNION	PRESSURE RATING
1"	SNA10	SMA10	SLA10	SJA10	SUA10	20 BAR
1.5"	SNA15	SMA15	SLA15	SJA15	SUA15	20 BAR
2"	SNA20	SMA20	SLA20	SJA20	SUA20	20 BAR
2.5"	SNA25	SMA25	SLA25	SJA25	SUA25	20 BAR
3"	SNA30	SMA30	SLA30	SJA30	SUA30	20 BAR
4"	SNA40	SMA40	SLA40	SJA40	SUA40	10 BAR

The standard joint rings (SJA--) supplied are Nitrile material. They are also available in EPDM (SJA -- E), VITON (SJA-- E), SILICON (SJA -- S).

SMS aseptic fittings features & advantages

- Versaline stainless steel SMS Aseptic union parts.
- All Versaline union parts are fully traceable.
- Excellent availability. Ex stock.

SMS aseptic fittings dimensions

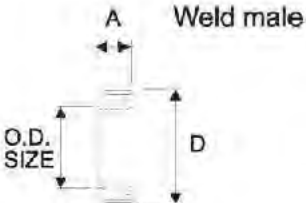

Weld male

Size	A	D
1"	19	40
1.1/2"	23	60
2"	23	70
2.1/2"	27	85
3"	27	98
4"	30	125

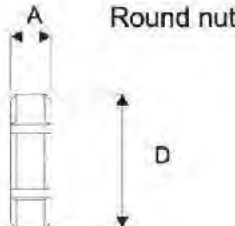

Round nut

Size	A	D
1"	19	51
1.1/2"	23	74
2"	24	84
2.1/2"	28	100
3"	30	114
4"	31	138

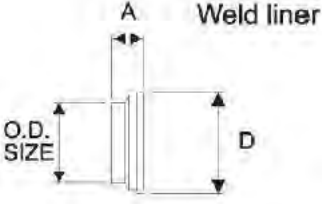

Weld liner

Size	A	D
1"	15.5	35.5
1.1/2"	16	55.0
2"	17	65.0
2.1/2"	17	80.0
3"	19	93.0
4"	19	118.0

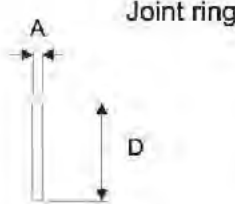

Joint ring

Size	A	D
1"	5.5	31
1.1/2"	5.5	47
2"	5.5	59
2.1/2"	5.5	73.5
3"	5.5	86
4"	5.5	116

Versaline clamp fittings



Applications: Pharmaceutical, Food and Dairy.

The Clamp union originated in America and is the standard used in the pharmaceutical industry. The union consists of two identical “ferrule” halves between which is a seal, profiled to give a true crevice free bore. The assembly is secured together by an outer clamp, which when tightened with the wing nut, compresses the seal ring by acting on the back tapered faces of the ferrule flanges. The assembly can be dismantled without the aid of tools.

SIZE	FERRULE 2 req'd per union	CLAMP	SEAL Available in Nitrile, EDPM, Silicon & Viton	FULL UNION Consists of 2 ferrules, 1 clamp, 1 seal	PRESSURE RATING At 250°F
0.5"	CF05F	CL07GRQ	CS05	CU05	50 BAR
0.75"	CF07F	CL07GRQ	CS07	CU07	50 BAR
1"	CF10F	CL15GRQ	CS10	CU10	50 BAR
1.5"	CF15F	CL15GRQ	CS15	CU15	50 BAR
2"	CF20F	CL20GRQ	CS20	CU20	50 BAR
2.5"	CF25F	CL25GRQ	CS25	CU25	40 BAR
3"	CF30F	CL30GRQ	CS30	CU30	30 BAR
4"	CF40F	CL40GRQ	CS40	CU40	25 BAR
6"	CF60F	CL60GRQ	CS60	CU60	20 BAR
8"	CF80F	CL80GRQ	CS80	CU80	15 BAR
10"	CF100F	CL100GRQ	CS100	CU100	12 BAR
12"	CF120F	CL120GRQ	CS120	CU120	10 BAR

Versaline clamp fittings dimensions

Ferrule - standard

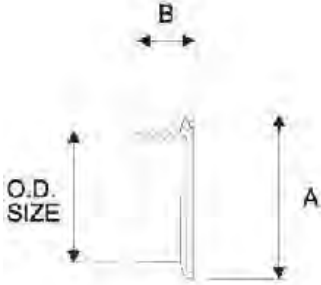

Size	A	B
1/2"	25.4	21.5
3/4"	25.4	21.5
1"	50.5	21.5
1.1/2"	50.5	21.5
2"	64.0	21.5
2.1/2"	77.5	21.5
3"	91.0	21.5
4"	119.0	21.5
6"	167.0	21.5
8"	217.0	21.5
10"	268.0	21.5
12"	320.0	21.5

Ferrule - long

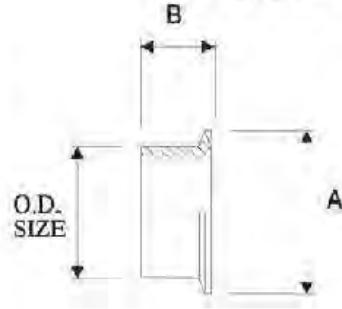

Size	A	B
1/2"	25.4	28.6
3/4"	25.4	28.6
1"	50.5	28.6
1.1/2"	50.5	28.6
2"	64.0	28.6
2.1/2"	77.5	28.6
3"	91.0	28.6
4"	119.0	28.6

There are 3 lengths of ferrule available. 12.5mm, 21.5mm (this is the standard length) and 28.5mm.

Metric and Nominal bore sizes are also available. Please enquire.

- Clamp blanks
- Orifice plates
- Strainers
- DIN/150/ Options on ferrules
- Controlled compression gaskets
- *Adaptors
- Double bolted clamps CLH

Stainless steel bends to BS4825



Applications: For use in all types of Food and Dairy pipework.

Manufactured to BS4825. Ordering Information: The part numbers for all available sizes are listed in the chart on the first page of this data sheet.

SIZE	WALL THICKNESS	GRADE 316 90°	GRADE 304 90°	GRADE 316 ONLY 45°
0.5"	1.6mm	BNP605	BNP405	-
0.75"	1.6mm	BNP607	BNP407	-
1"	1.6mm	BNP610	BNP410	BFP10
1.5"	1.6mm	BNP615	BNP415	BFP15
2"	1.6mm	BNP620	BNP420	BFP20
2.5"	1.6mm	BNP625	BNP425	BFP25
3"	1.6mm	BNP630	BNP430	BFP30
4"	2mm	BNP640	BNP440	BFP40

Stainless steel bends to BS4825 dimensions

Nominal dimensions - mm

Standard 1.1/2D welding bends

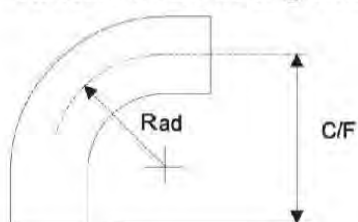

Size	C/F	Rad	Wall
1"	65	38.1	1.6
1.1/2"	85	57.2	1.6
2"	110	76.2	1.6
2.1/2"	135	95.3	1.6
3"	155	114.3	1.6
4"	195	152.4	2.0

Hand welding bends, 1D and 2D, no straights

D	CODE	SIZE	C/F	RAD	WALL
1.5D	BBN10	1"	44mm	38.1mm	1.6mm
1.5D	BBN15	1.5"	64mm	57.2mm	1.6mm
1.5D	BBN20	2"	89mm	76.2mm	1.6mm
1.5D	BBN25	2.5"	114mm	95.3mm	1.6mm
1.5D	BBN30	3"	134mm	114.0mm	1.6mm
1.5D	BBN40	4"	174mm	152mm	2.0mm

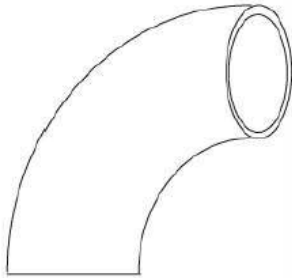

D	CODE	SIZE	C/F	RAD	WALL
1D	BSN10	1"	55mm	25.4mm	1.6mm
1D	BSN15	1.5"	70mm	38.1mm	1.6mm
1D	BSN20	2"	82mm	50.8mm	1.6mm
1D	BSN25	2.5"	105mm	63.5mm	1.6mm
1D	BSN30	3"	110mm	76.2mm	1.6mm
1D	BSN40	4"	110mm	101.6mm	2.0mm

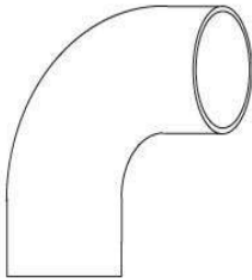

D	CODE	SIZE	C/F	RAD	WALL
2D	BLN10	1"	80mm	50.8mm	1.6mm
2D	BLN15	1.5"	105mm	76.2mm	1.6mm
2D	BLN20	2"	130mm	101.6mm	1.6mm
2D	BLN25	2.5"	160mm	127.0 mm	1.6mm
2D	BLN30	3"	215mm	152.4mm	1.6mm
2D	BLN40	4"	-	-	-

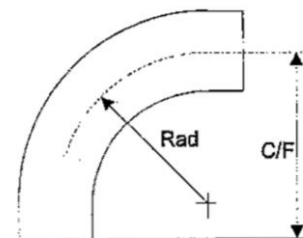

D	CODE	SIZE	C/F	RAD	WALL
2D	BLND10/3	1"	124mm	70mm	1.6mm
2D	BLND15/6	1.5"	200mm	152.4mm	1.6mm
2D	BLND20/6	2"	200mm	152.4mm	1.6mm
2D	BLND25/6	2.5"	215mm	152.4 mm	1.6mm
2D	BLND30/6	3"	215mm	152.4mm	1.6mm
2D	BLND40/8	4"	235mm	200mm	1.6mm

D	CODE	SIZE	C/F	RAD	WALL
2D	BLNP20/4	2"	130mm	-mm	1.6mm
2D	BLNP20/6	2"	155mm	152.4 mm	1.6mm
2D	BLNP25/6	2.5"	170mm	152.4mm	1.6mm
2D	BLNP3/6	3"	160mm	152.4mm	1.6mm

Bends for jacketing

Jacketed bend assemblies are available in component form.
 All bends are specially produced to ensure concentricity and dimensional accuracy.

SIZE	CODE	R	A	B	NOTES
1.5" x 1"	JB1510/1.5	38.1	65	8	
1.5" x 1"	JB1510/3	76.2	124	7	
2" x 1"	JB2010/3	76.2	124	47	
2" x 1"	JB2010/6	150	180	25	
2" x 1.5"	JB2015/3	76.2	105	16	
2" x 1.5"	JB2015/6	152.4	200	33	
2.5" x 1.5"	JB2515/6	152.4	200	45	
2.5" x 2"	JB2520/4	101	130	13	
2.5" x 2"	JB2520/6	152.6	200	33	
3" x 2"	JB3020/3	76.2	110	0	
3" x 2"	JB3020/6	152.4	200	40	
3" x 2.5"	JB3025/6	150	215	43	
3" x 2.5"	JB3025/12	304.8	355.6	13	
4" x 3"	JB4030/12	304.8	355.6	13	
4" x 3"	JB4030/6	150	215	8	
4" x 3"	JB4030/4.5	114	135	12	

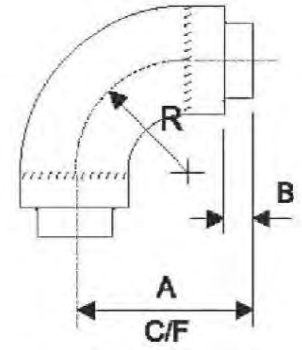

More sizes (including metric sizes) on next page and also closure end plates information.

SIZE	CODE	R	A	B	NOTES
4.5" x 4"	JB4540/6	152.4	195	43	
129 x 104	JB5040/8	200	250	56	
154 x 104	JB6040/8	200	250	19	
54 x 76	JBM3020/3	3"	-	-	
54 x 76	JBM3020/6	6"	-	-	
70 x 89	JBM8965/70	-	-	-	
70 x 104	JBM104065/160	160	-	-	
84 x 104	JBM104080/120	4.5"	-	-	
104 x 129	JBM5040/8	8"	-	-	
104 x 129	JBM5040/8S	8" Short	-	-	
104 x 154	JBM6040/8	8"	-	-	
154 x 203	JBM8060	9"	-	-	

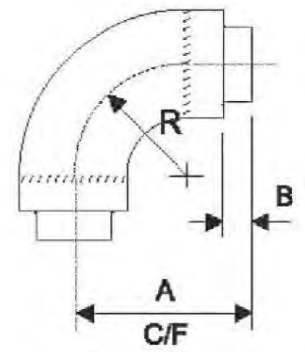

Jacket bend closure plate discs. 316 Stainless steel. All sizes in stock.

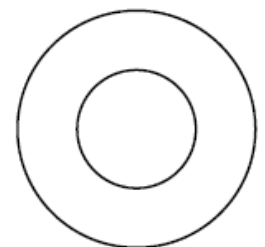

Equal and pulled tees



Application: Food and Dairy.

Where there is a requirement to branch off from a pipework run with the same size tubing. Equal and pulled tees are both suitable for orbital welding, however the pulled type can only be orbital welded at the ends along the main run of the tee. Ordering Information: The part numbers for all available sizes are listed in the chart on the first page of this datasheet. Grade of stainless is 316L Manufactured to BS4825.

TYPE	SIZE	CODE
EQUAL	1"	TEP610
EQUAL	1.5"	TEP615
EQUAL	2"	TEP620
EQUAL	2.5"	TEP625
EQUAL	3"	TEP630
EQUAL	4"	TEP640
PULLED	1"	TPP10
PULLED	1.5"	TPP15
PULLED	2"	TPP20
PULLED	2.5"	TPP25
PULLED	3"	TPP30
PULLED	4"	TPP40

Equal and pulled tees dimensions

Equal tee, 316

Size	C/F	A	Wall
1"	44	88	1.6
1.1/2"	64	128	1.6
2"	89	178	1.6
2.1/2"	114	228	1.6
3"	134	268	1.6
4"	195	390	2.0

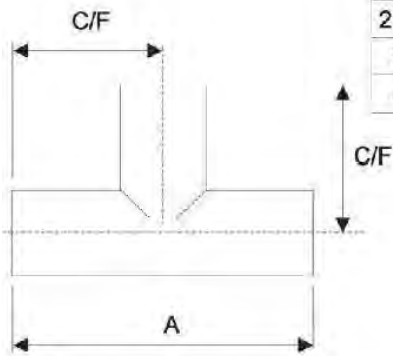

Pulled tee 316

Size	C/F	A	B	Wall
1"	44	88	15	1.6
1.1/2"	64	128	22	1.6
2"	89	178	28	1.6
2.1/2"	114	228	35	1.6
3"	134	268	41	1.6
4"	195	390	55	2.0

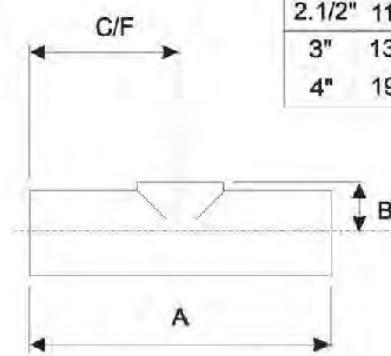

Stainless steel reducing tees



Applications: Food and dairy

Where there is a requirement to branch off from a certain size of pipework with a smaller diameter pipework size. **Ordering information:** The part numbers for all available sizes are listed in the chart on the first page of this data sheet.

SIZE	BRANCH SIZE	CODE
0.75"	0.5"	TRP0705
1"	0.5"	TRP1005
1"	0.75"	TRP1007
1.25"	0.75"	TRP1207
1.5"	0.5"	TRP1505
1.5"	0.75"	TRP1507
1.5"	1"	TRP1510
2"	0.5"	TRP2005
2"	0.75"	TRP2007
2"	1.0"	TRP2010
2.5"	0.75"	TRP2507
2.5"	1"	TRP2510

SIZE	BRANCH SIZE	CODE
2.5"	1.5"	TRP2515
2.5"	2.0"	TRP2520
3"	0.5"	TRP3005
3"	0.75"	TRP3007
3"	1"	TRP3010
3"	1.5"	TRP3015
3"	2"	TRP3020
3"	2.5"	TRP3025
4"	1"	TRP4010
4"	1.5"	TRP4015
4"	2"	TRP4020
4"	2.5"	TRP4025

Stainless steel reducing tees features and benefits

- Manufactured from Grade 316 Stainless steel.
- Manufactured to BS4825.
- Fully traceable.
- Clearly marked.
- Length of each leg of tee makes them suitable for Orbital Welding.

Versaline Grade 304L and 316L stainless steel tubing



Versaline Hygienic Tube – manufactured to the highest international tube standards to provide customers with sustainable and reliable piping solution. Only available from HpE Process, it ticks the boxes that other tube suppliers don’t.

Versaline hygienic tube is supplied in the polished condition and marked indelibly with heat numbers, material spec and tube spec. This allows the customer to check what he is getting and that it is to international standards. In short that it meets his own requirements. Tube that is not marked is not traceable or identifiable and in some cases is not even hygienic tube.

All Versaline hygienic tube is pickled and passivated internally. Passivation removes residual iron from the manufacturing process and renews the ‘passive layer’ on the tube. The passive layer is what gives stainless steel its corrosion resistance and hygienic properties. Any tube that is not passivated is more prone to chemical attack and will have substantially shorter life span. Especially where Chlorine based sanitisers are used. For the end user this means a reliable and long-lasting solution.

All Versaline hygienic tube is hydrostatically tested and certified – for customer peace of mind.

Versaline annealed hygienic tube is heat treated and provides users with the ultimate resistance to stress cracking and stress corrosion cracking. It can be manipulated as required and is quite simply the ‘highest quality/unit cost’ hygienic tube available. **Versaline** un-annealed hygienic tube is the cost-effective answer for installations where cost is more of an issue and stress/stress corrosion are unlikely. It should not be used for bending or where high stress could occur.

SIZE	CODE	CODE	CODE	CODE
	316 ANNEALED EN30157	316 UNANNEALED A270	304 ANNEALED EN30157	304 UNANNEALED A270
1"	TUP610	TUP610/1.5U	TUP410	TUP410/1.5U
1.5"	TUP615	TUP615/1.5U	TUP415	TUP415/1.5U
2"	TUP620	TUP620/1.5U	TUP420	TUP420/1.5U
2.5"	TUP625	TUP625/1.5U	TUP425	TUP425/1.5U
3"	TUP630	TUP630/1.5U	TUP430	TUP430/1.5U
4"	TUP640	TUP640/1.5U	TUP440	TUP440/1.5U

Versaline stainless steel tubing features and benefits



- Tube is hydrostatically pressure tested.
- Manufactured to A270 / DIN 11850 standard and EN10357.
- Clearly etch marked for easy identification and traceability.
- Available in fully annealed and unannealed.
- Grade 304L and 316L.

For easy identification whilst on the shelf, the tubing is individually sleeved in polythene. Red coloured polythene denotes grade 316L, Clear polythene denotes grade 304L.

Further to this, the tube ends are capped with blue and clear plastic end caps.
Blue denotes unannealed.
Clear denotes annealed.

Concentric and Eccentric reducers



All 316L Stainless steel. All length measurements +/-1mm.

We can also offer the following sizes which do not appear in the above chart: (Concentric and Eccentric versions).

0.5" x 0.25", 0.75" x 0.5", 1" x 0.25", 1" x 0.375", 1.0" x 0.5", 1" x 0.75", 1.25" x 0.5", 1.25" x 0.75", 1.25" x 1.0", 1.5" x 0.5", 1.5" x 0.75", 1.5" x 1.25", 2" x 1.5", 2" x 1.5", 2" X 0.75", 4" X 1", 4" X 1.5".

We can also supply larger and metric sizes. Please contact us for details.

SIZE	CONCENTRIC CODE	CONCENTRIC LENGTH	ECCENTRIC CODE	ECCENTRIC LENGTH
1.5" X 1"	CRP1510	28mm	ERP1510	38mm
2" X 1"	CRP2010	52mm	ERP2010	55mm
2" X 1.5"	CRP2015	38mm	ERP2015	33mm
2.5" X 1"	CRP2510	82mm	ERP2510	78mm
2.5" X 1.5"	CRP2515	65mm	ERP2515	67mm
2.5" X 2"	CRP2520	37mm	ERP2520	35mm
3" X 1"	CRP3010	110mm	ERP3010	102mm
3" X 1.5"	CRP3015	81mm	ERP3015	77mm
3" X 2"	CRP3020	54mm	ERP3020	68mm
3" X 2.5"	CRP3025	37mm	ERP3025	43mm
4" X 1.5"	CRP4015	135mm	ERP4015	130mm
4" X 2"	CRP4020	110mm	ERP4020	102mm
4" X 2.5"	CRP4025	80mm	ERP4025	75mm
4" X 3"	CRP4030	54mm	ERP4030	71mm

Versaline stainless steel butterfly valves



Applications:

- The Versaline Butterfly valve is available for manual operation or with a vertical actuator.
- The standard seal is EPDM with the option of VITON.
- Plain ended and RJT connections available ex-stock.
- CE Marked, spares available, full traceability.

Operating Conditions:

- Integral locking device for use with padlock.
- Up to 10 Bar working pressure.
- Mirror Polished Spindle as standard.
- Notch plate allows easy conversion from 2 position on/off operation to 5 position flow control operation.

Ordering information:

- Choice of EPDM, VITON, NBR, SILICON seals
- Plain Ended, RJT, IDF, Clamp, SMS connections available. (plain ended and RJT male ended, Tri-clamp available ex stock).
- Manual handle or Vertical actuator operation.

For all technical information see chart on following pages (Product codes are bold).

SIZE	CONNECTION	CONNECTION	CONNECTION	CONNECTION	CONNECTION	CONNECTION
1"	RJT VBR10/89	IDF VBI10/89	CLAMP VBC10/89	SMS VBSA10/89	DIN VBD10/89	PLAIN VBP10/89
1.5"	RJT VBR15/89	IDF VBI15/89	CLAMP VBC15/89	SMS VBSA15/89	DIN VBD15/89	PLAIN VBP15/89
2"	RJT VBR20/89	IDF VBI20/89	CLAMP VBC20/89	SMS VBSA20/89	DIN VBD20/89	PLAIN VBP20/89
2.5"	RJT VBR25/89	IDF VB25/89	CLAMP VBC25/89	SMS VBSA25/89	DIN VBD25/89	PLAIN VBP25/89
3"	RJT VBR30/89	IDF VBI30/89	CLAMP VBC30/89	SMS VBSA30/89	DIN VBD30/89	PLAIN VBP30/89
4"	RJT VBR40/89	IDF VBI40/89	CLAMP VBC40/89	SMS VBSA40/89	DIN VBD40/89	PLAIN VBP40/89

HpE Process Product Catalogue
Face to Face dimensions
Connection: RJT (Approximate values only)

SIZE	ID (MM)	OD (MM)	L (MM)	H (MM)
1"	22.1	-	70	61
1.5"	34.9	-	80	64.3
2"	47.5	-	80	74.3
2.5"	60.3	-	80	77.6
3"	72.9	-	80	84.8
4"	97.6	-	90	101.7

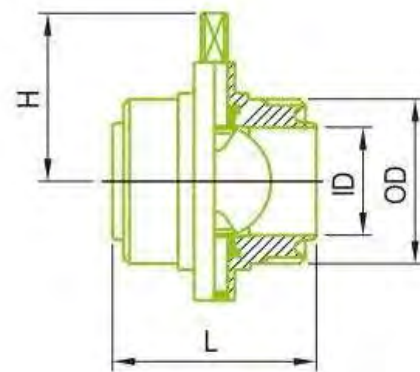

Connection: Plain (Approximate values only)

SIZE	ID (MM)	OD (MM)	L (MM)	H (MM)
1"	22.1	25.4	52	61
1.5"	34.8	38.1	52	64.3
2"	47.5	50.8	54	74.3
2.5"	60.2	63.5	56	77.6
3"	72.9	76.2	60	84.8
4"	97.6	101.6	72	101.7

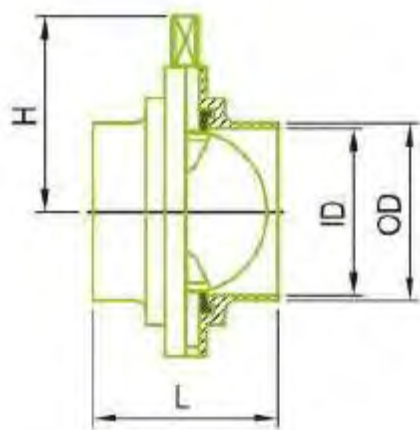

Connection: Clamp (Approximate values only)

SIZE	ID (MM)	OD (MM)	L (MM)	H (MM)
1"	22.1	50.5	90	61
1.5"	34.8	50.5	90	64.3
2"	47.5	64	95	74.3
2.5"	60.2	77.5	97	77.6
3"	72.9	91	103	84.8
4"	97.6	119	103	101.7

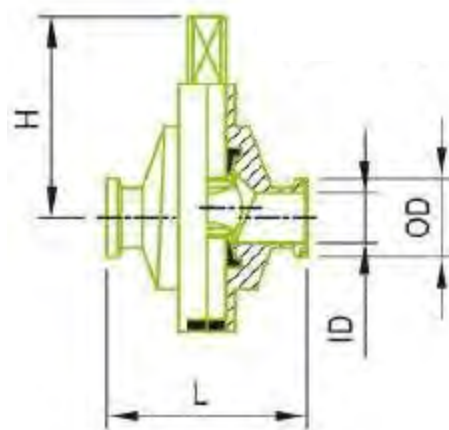

Connection: IDF (Approximate values only)

SIZE	ID (MM)	OD (MM)	L (MM)	H (MM)
1"	22.1	50.5	96	61
1.5"	34.9	50.5	96	64.3
2"	47.5	64	100	74.3
2.5"	60.3	77.5	100	77.6
3"	73	91	126	84.8
4"	97.6	119	130	101.7

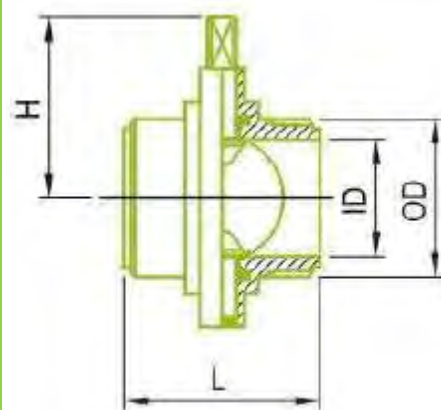

Connection: DIN (Approximate values only)

SIZE	ID (MM)	OD (MM)	L (MM)	H (MM)
1"	22	25.5	110	61
1.5"	34	38	120	66.7
2"	47.3	50.7	124	74.3
2.5"	60.3	63.5	100	77.6
3"	72.8	76	164	91.6
4"	100	104	180	101.7

Connection: SMS (Approximate values only)

SIZE	ID (MM)	OD (MM)	L (MM)	H (MM)
1"	22.1	25.4	96	61
1.5"	35	38	96	64.3
2"	47.5	51	100	74.3
2.5"	60.3	64.4	100	77.6
3"	73	76	126	84.8
4"	96.5	101.5	130	101.7

Versaline butterfly valve handle options

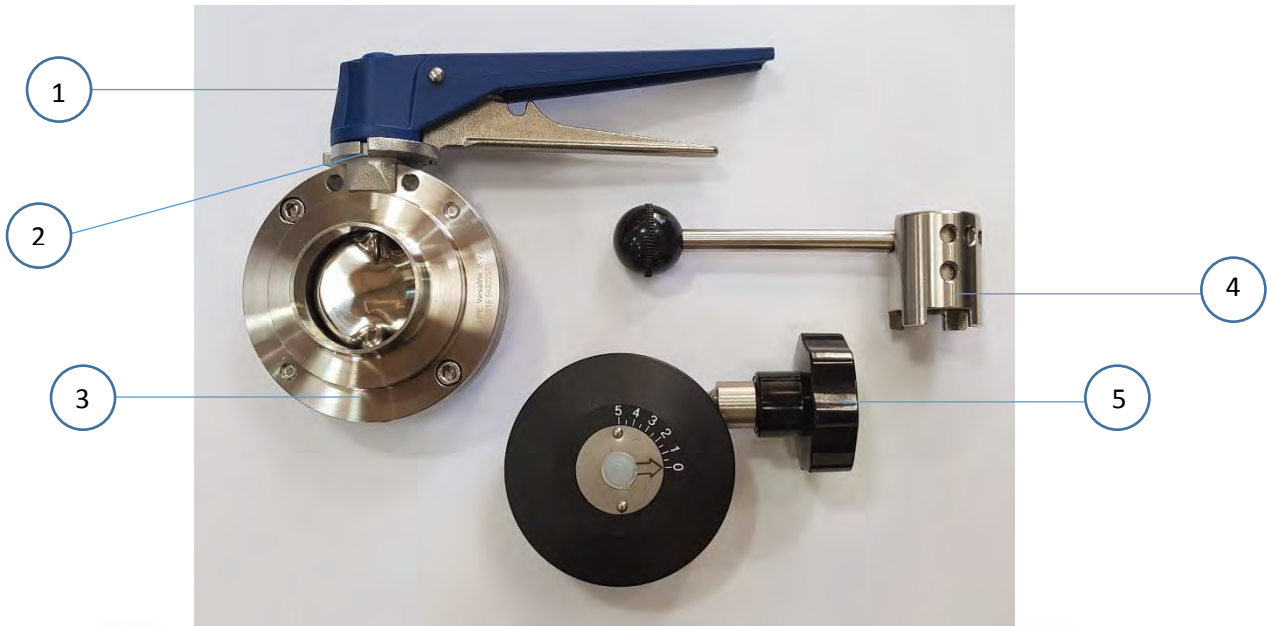

- 1** Integral locking device for use with padlock
- 2** Notch plate allows easy conversion from 2 position on/off operation to 5 position flow control operation
- 3** Low cost Versaline E valve is suitable for use at up to 10 bar pressure for most applications
The optional forged Versaline F valve is 15 bar rated
Optional ATEX approval on Versaline F valve for use in category 2, Zone 1 areas
Disc is mirror polished as standard
Choice of EPDM or Viton seals
Full traceability
- 4** Optional stainless steel 'pull' lever for positive shut off
- 5** Or REMI Micrometric flow control handle

Versaline butterfly valve technical data

(Change the title to Versaline Butterfly Actuator)

Code	Valve Size	Torque Figure
VBACT1/89/E1	1"	15
VBACT1/89/E1	1.5"	15
VBACT1/89/E1	2"	15
VBACT1/89/E1	2.5"	20
VBACT1/89/E1	3"	25
VBACT4/89E104	4"	30

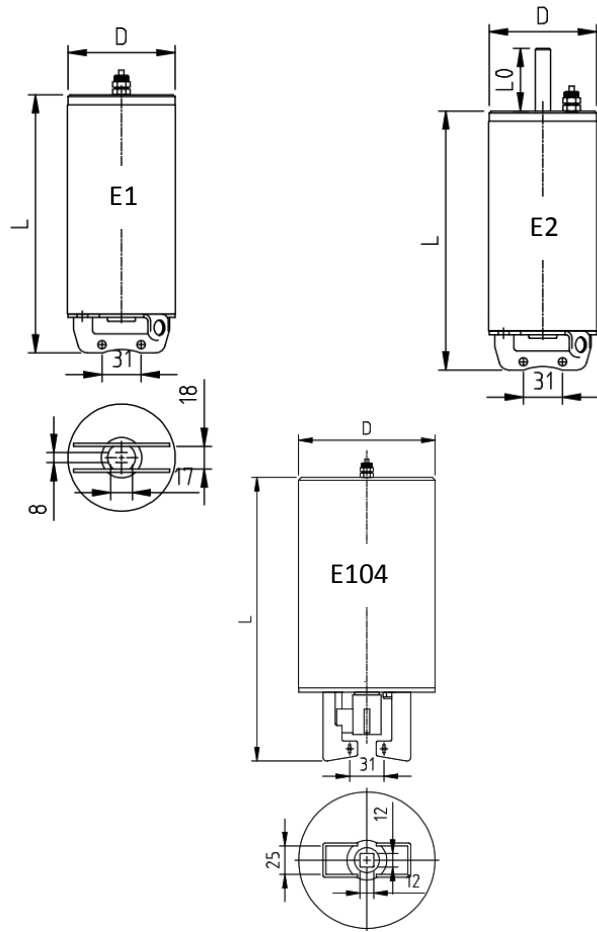

Valve Technical Data

		Nominal valve size					
		1"	1.5"	2"	2.5"	3"	4"
Materials	Wetted steel parts	316L stainless steel					
	Finish	Semi-bright					
	Other steel parts	304 stainless steel					
	Seal	EPDM standard, Viton option					
Technical Data	Max product pressure	10 BAR					
	Min product pressure	Full vacuum					
	Temperature range	-10°C to +95°C					
	Connection type	Plain end, RJT, IDF					
	Max torque open & close (Nm)	15Nm	15Nm	15Nm	20Nm	25Nm	30Nm

Actuator Technical Data

	Actuator Model		
	E1	E2 (with solenoid and 2 x proximity switch)	E104
Actuator body	304		
Piston	POM		
Seal	NBR		
Dimension D	85mm		120mm
Dimension L	205mm		250mm
Dimension L0	N/A	50.5	N/A
Weight	3.85Kg		4.7Kg
To suit valve	1" to 3"		4"
Shut off speed	1.5 Sec		1.7 Sec
Max air pressure	7 Bar		
Min air pressure NC and NO	5 Bar		
Temperature range	-10°C to +95°C		
Air consumption - free air (L)	0.24 x P (Bar)		0.55 x P (Bar)
Signal transfer	M12 screw proximity switch (PNP or NPN)	M12 screw proximity switch (PNP or NPN or control box)	M12 screw proximity switch

Versaline Control Head



IP65 RATED

Versaline Control Head advantages

- Adaptable for all standard actuators.
- Retrofitting is possible.
- Adaptors for third party products are available on request.
- Faster changing of control units meaning down times are considerably reduced.
- Easy assembly.
- User friendly connection technology.
- Adjustment of proximity switches is not necessary anymore.
- Visual position indicator giving clear indication of valve status.
- Free rotatability of the control head.
- Shape design with a robust housing.

For control head mounting instructions see following page.

Air pressure

Std 24V DC

Power consumption

1 solenoid, 2 sensors

0 solenoid, 2 sensors

Versaline Control Head mounting instructions

Loosen the three set screws (8) and remove adaptor (1) from the baseplate (3)

Screw in the adaptor (1) with the banjo screw (10) into the G1/8" compressed air connection of the pneumatic cylinder. Make sure that the O ring (20) is mounted.

Set the control unit onto the adaptor (1) and turn the Baseplate (3) to the desired position.

Tighten the three screws (8) to firmly connect the TOP-LED with the actuator.



Assembly of control unit TOP-LED

Versaline 2 piece stainless steel BSP female ball valve



Applications:

Abrasive products (the valve components can withstand passage of abrasive medium)

Operating conditions:

Pressure rating 1000 PSI (Wog). Replaceable PTFE seal (230°C max).

Ordering information:

The part numbers for each available size are listed in the chart below.

CODE	SIZE	CONNECTION TYPE	SEAL MATERIAL
VBAB/2/02F	1/4"	BSPF	PTFE
VBAB/2/05F	1/2"	BSPF	PTFE
VBAB/2/07F	3/4"	BSPF	PTFE
VBAB/2/10F	1"	BSPF	PTFE
VBAB/2/15F	1X1/2"	BSPF	PTFE
VBAB/2/20F	2"	BSPF	PTFE

Versaline 2 piece BSP female ball valve features & advantages



PTFE seal

Removable end so access can be gained to internal PTFE seal



Pressure rating 100PSI (1000 WOG)

Removable end.

Stainless Steel Construction

Versaline 3 piece stainless steel ball valve



Applications: For food and dairy.

Where there is a requirement for sanitary on/off full-bore valve. Abrasive products (the valve components can withstand passage of abrasive medium).

Operating conditions:

Pressure rating 1000 PSI (1000 WOG). PTFE seal (230°C max). Piggable.

Ordering information:

These valves can be supplied with a variety of pipe connection types. The connection components can also be supplied separately for the user to weld on. The common pipe connection types we stock are RJT, IDF, DIN, SMS, SMS Aseptic and Clamp. Please ask at the time of ordering.

These valves are Sanitary, not hygienic or suitable for CIP.

PIPE SIZE	CONNECTION Standard	CONNECTION				SEAL MATERIAL
1/2"	PLAIN ENDED VBAPE05/89	RJT	IDF	DIN	SMS	PTFE
3/4"	PLAIN ENDED VBAPE07/89	RJT	IDF	DIN	SMS	PTFE
1"	PLAIN ENDED VBAPE10/89	RJT VBARE10/89	IDF	DIN	SMS	PTFE
1.5"	PLAIN ENDED VBAPE15/89	RJT VBARE15/89	IDF	DIN	SMS	PTFE
2"	PLAIN ENDED VBAPE20/89	RJT VBARE20/89	IDF	DIN	SMS	PTFE
2.5"	PLAIN ENDED VBAPE25/89	RJT	IDF	DIN	SMS	PTFE
3"	PLAIN ENDED VBAPE30/89	RJT VBARE30/89	IDF	DIN	SMS	PTFE
4"	PLAIN ENDED VBAPE40/89	RJT VBARE40/89	IDF	DIN	SMS	PTFE

Also available: tri-clamp ends, flanged ends (PN16, ASA150, Table)

Versaline 3 piece ball valve features & advantages

- Full bore opening.
- To enable left/right hand opening simply remove the Allen screw (shown top right of the image) and refit in the opposite hole. (Note: not the diagonally opposite hole).
- Integral handle locking device.



- Integral handle locking device.
- 3 piece body construction (to enable inlet ends to be removed for welding purposes).
- Internal PTFE encapsulated seal.



Versaline 3 piece ball valve technical data

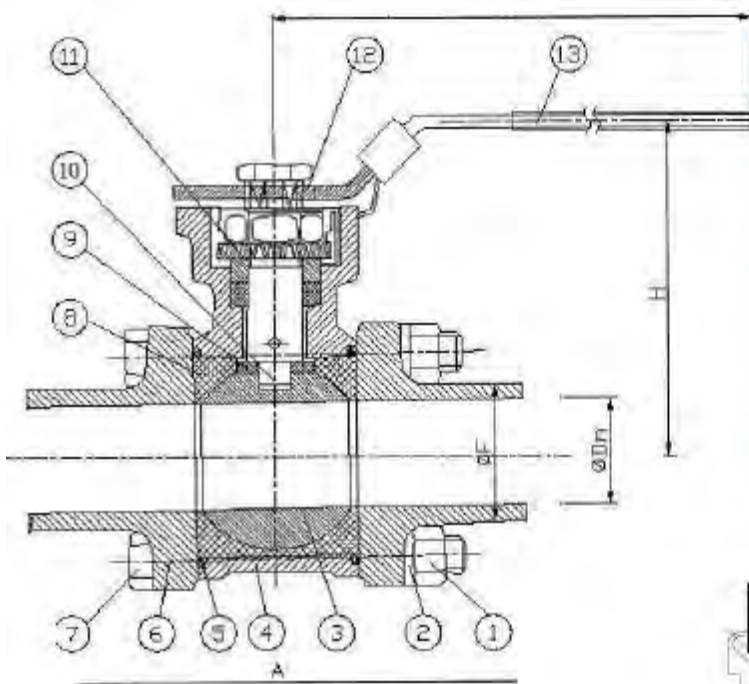

NUMBER	DESCRIPTION
1	Nut
2	Washer
3	Ball
4	Body
5	Gasket
6	Cap
7	Bolt
8	Ball Seat
9	Thrust Washer
10	Stem
11	Belleville Washer
12	Handle
13	Needle Sleeve

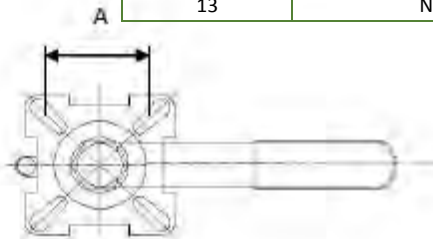

ISO pad. (F5)

Measurement A (PCD)

- 1/2" and 3/4" valve sizes 40mm
- 1" valve size 45mm
- 1.5" valve size 60mm
- 2" valve size 65mm
- 2.5", 3" and 4" valve sizes 90mm

SIZE	Dn	A	H	F	J	Square Shaft Size (MM)	Torque (Nm)
1/2"	9.7	89.4	57	12.7	57	9 x 9	15
3/4"	16	100.5	66	19.05	66	9 x 9	15
1"	22.4	114.5	85	25.4	85	11 x 11	20
1 x 1/2"	35.1	137.5	116	38.1	116	14 x 14	30
2"	47.8	156.0	125	50.8	125	14 x 14	35
2 x 1/2"	59.5	183.0	150	63.5	150	14 x 14	45
3"	72.2	200.0	150	76.2	150	17 x 17	60
4"	97.6	240.0	160.0	101.6	160	17 x 17	70

Versaline 3 way ball valve



Applications: Food and Dairy.

The Versaline 3-way ball valve is suitable for use where there is a requirement for a sanitary full bore valve.

Abrasive products (the valve components can withstand the passage of abrasive medium).

Operating Conditions:

1000 WOG. PTFE Seal (230°C max)

Piggable (except the centre branch)

Required air pressure for actuator is 4-7 bar

Ordering Information:

The part numbers for each available size are listed in the chart below. These valves can be supplied with a variety of pipe connection types. The connection components can also be supplied separately for the user to weld on. The common pipe connection types we stock are RJT, IDF, DIN, SMS, SMS Aseptic and clamp.

These valves are Sanitary, not Hygienic or suitable for CIP.

For a fully Hygienic 3-way ball valve please enquire about our EHEDG 3-way shutter valve.

CODE	SIZE	PORT TYPE	TORQUE
VBAPE – 3/07T/89	0.75"	T	15NM
VBAPE – 3/10T/89	1"	T	20NM
VBAPE – 3/15T/89	1.5"	T	30NM
VBAPE – 3/20T/89	2"	T	35NM
VBAPE – 3/25T/89	2.5"	T	45NM
VBAPE – 3/30T/89	3"	T	60NM
VBAPE – 3/40T/89	4"	T	70NM

Versaline 3 way ball valve technical data

D DIMENSION (K/M.)

SIZE	DN	ISO-5211	W	H1	H	C	L	Ød	Ød2	R	ØØØE
1/2	15	F03/F04	143	26	44.5	9	118	9.5	25.4	12.7	9
3/4	20	F03/F04	143	26	48	9	127	15.8	25.4	19.1	9
1	25	F04/F05	160	32	59	11	152.4	22.2	50.4	25.4	11
1-1/2	40	F05/F07	187	42	72	14	175	35	50.4	38.1	14
2	50	F05/F07	187	42	82	14	190	47.6	63.9	50.8	14
2-1/2	65	F07/F10	400	37	100	17	228	60.2	77.5	63.5	17
3	80	F10/F12	400	37	125.5	23	260	73	90.9	76.2	22
4	100	F10/F12	400	37	132.5	23	318	97.4	118.9	101.6	22
											1900

Ø MATERIAL OF CONSTRUCTION

ITEM	PARTS	MATERIAL	Qty
1	BODY	A351-CF8M/CF3M/BPE	1
2	CAP	A351-CF8M/CF3M/BPE	4
3	BALL	A351-CF8M/CF3M/BPE	1
4	SEAT	PTFE/TFM-16000P/MD FF)	4
5	GASKET	PTFE/TFM-16000P/MD FF)	2
6	THRUST WASHER	PTFE/TFM-16000P/MD FF)	1
7	O-RING	VITON	1
8	STEM PACKING	PTFE/TFM-15000P/MD FF)	1
9	RING	AISI 304	1
10	BEVEL WASHER	AISI 304	2
11	STOP PIN	AISI 304	1
12	NUT	AISI 304	2
13	STEM	AISI 316/316L	1
14	HANDLE	AISI 304	1
15	SPRING WASHER	AISI 304	16
16	BOLT	AISI 304	16
17	PREVALING DEVICE	AISI 304	1
18	NUT	AISI 304	1

PRESSURE-TEMPERATURE RATING

Full cavity filled seats
 Blow-out proof stem
 Investment casting body and cap
 1000PSI(63BAR) 1/2"~2"
 800PSI(40BAR) 2-1/2"~4"
 standard/Butt weld end
 Direct mounting pad ISO 5211 Square stem
 Inside port Ra0.4

ISO 5211

T PORT

L PORT

1/2"~2"

2-1/2"~4"

RUTT WELD

T-CLAMP

Versaline ball valve actuator

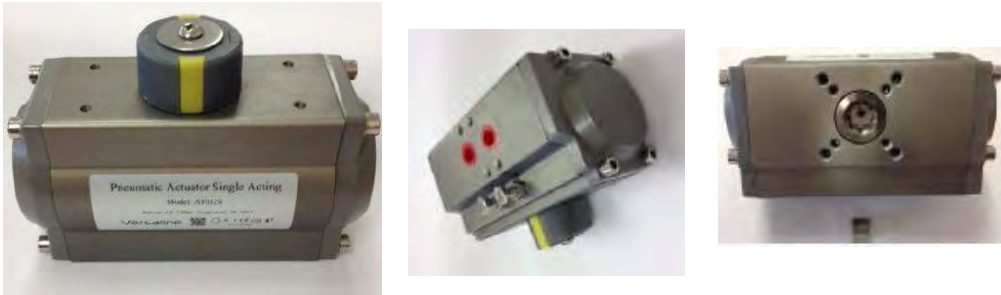

Applications:
 Single acting spring return actuator for use with Versaline Ball Valves, option air/air.

Operating conditions:
 Air operated, spring return with top mounted easily visible position indicator.

Ordering information:
 See information in chart below for part numbering/size ordering information.

CODE	FITS BALL VALVE SIZE
VBAACT05-07/89	1/2" and 3/4"
VBAACT10/89	1"
VBAACT15/89	1.5"
VBAACT20/89	2"
VBAACT25/89	2.5"
VBAACT30/89	3"

24V DC Solenoid

CODE	DESCRIPTION	
VBAACT/SOL/24D/89	3/2	Air/Spring
VBAACT/SOL52/89	5/2	Air/Air

Top mounted 24V DC proximity sensors

CODE	DESCRIPTION	
VBAACT/2PS/24D/89	-	2 x 24VDC proximity sensors including puck

PCD & thread size of actuator mounting holes

VALVE SIZE	INNER HOLES: PCD/SIZE	OUTER HOLES: PCD/SIZE
1/2" and 3/4"	36mm / 5mm	50mm / 6mm
1"	50mm / 6mm	70mm / 8mm
1.5"	50mm / 6mm	70mm / 8mm
2"	50mm / 6mm	70mm / 8mm
2.5"	70mm / 8mm	101mm / 10mm
3"	70mm / 8mm	101mm / 10mm

Versaline ball valve actuator shaft adaptor



The actuators are a female star drive as standard. Where applicable, an adaptor piece is supplied.

Non return valve



Applications: Food and Dairy
 Where there is a requirement for a hygienic design non-return valve.

Operating conditions:
 Required differential pressure for opening of the valve when fitted in a vertical pipe is approx. 6kpa (0.06bar).

Ordering information:
 Please state the following when ordering: Pipe-work size and connection type required.

CODE	SIZE	DIMENSIONS (mm)	
		D	L
VNRP10V/89	1"	85	95
VNRP15V/89	1.5"	114	108
VNRP20V/89	2"	127	108
VNRP25V/89	2.5"	157	108
VNRP30V/89	3"	161	108
VNRP40V/89	4"	220	120

ITEM	DESCRIPTION
1	Body
2	Disc
3	Seal
4	Spring
5	Plate
6	Ring
7	Clamp

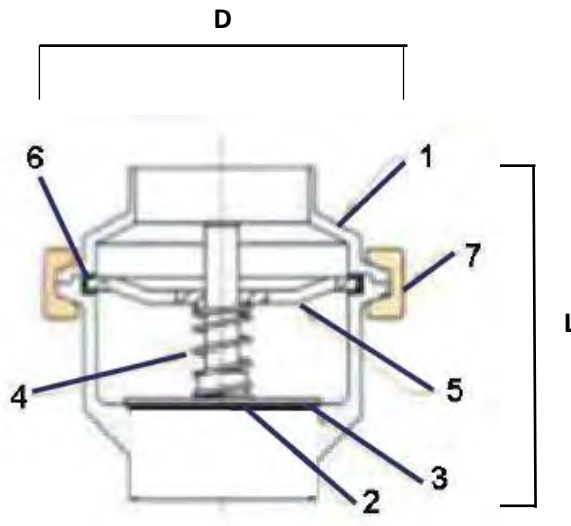

The image on the left shows the optimal fitted position. It is also permissible to fit the valve in a horizontal position.
 Material: AISI 316.



Pressure Drop / Capacity Chart

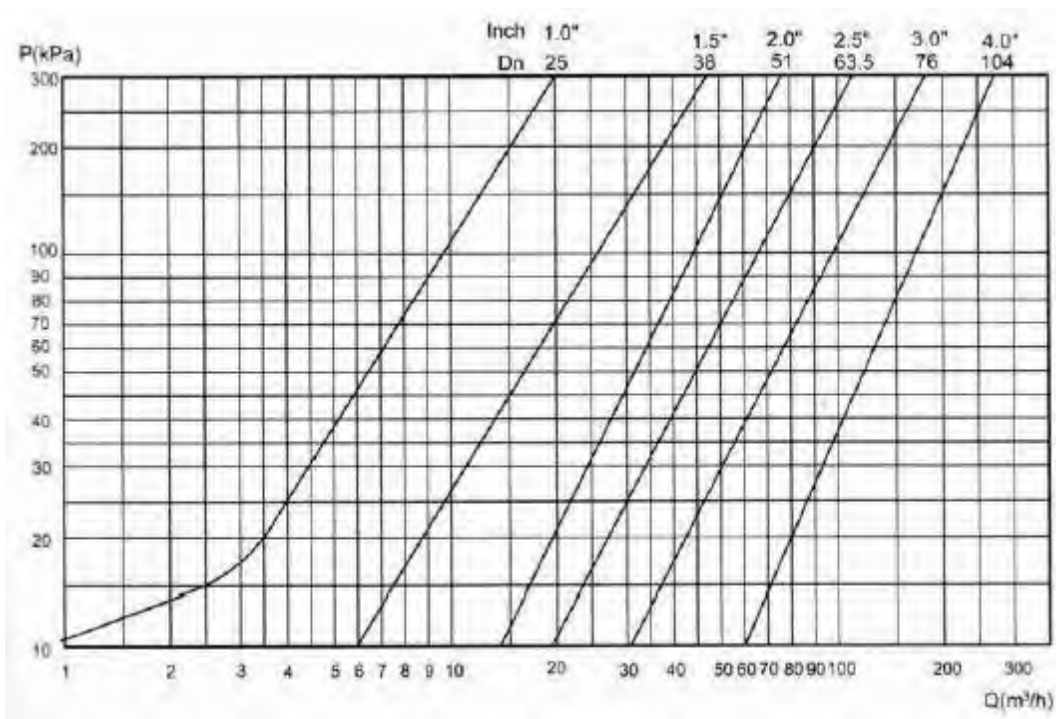

IMPORTANT

When welding the valves take care not to put too much heat on the weld. Too much heat will cause distortion of the valve and lead to leakages.

Regulating valve

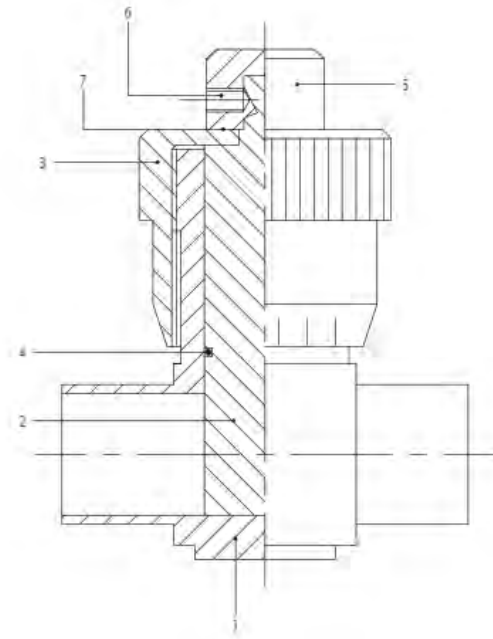

1. Valve Casing
2. Head Seal
3. Adjusting device
4. OR seal ring
5. Locking device
6. Dowel
7. Washer



More flow control valve 316L /EPDM
Coding:

POS	1" 25	D 25 28	D 32 34	1 1/2" 38	D 40 40	2" 51	D 50 52	2 1/2" 63	D 65 70	3" 76	MATERIAL	
CODE	VREGP610/3			VREGP615/3			VREGP620/3					
1	25	28	34	38	40	51	52	63	70	76	316L	01
2	25/28	25/28	34	38/40	38/40	51/52	51/52	63	70	76	316L	02
3	25/28	25/28	34	38/40	38/40	51/52	51/52	63	70	76	316L	03
4	3081	3081	4093	4118	4118	6150	6150	6187	6212	6237	316L	
5	25/76	25/76	25/76	25/76	25/76	25/76	25/76	25/76	25/76	25/76	316L	05
6	8X10	8X10	8X10	8X10	8X10	8X10	8X10	8X10	8X10	8X10	316L	
7	25/76	25/76	25/76	25/76	25/76	25/76	25/76	25/76	25/76	25/76	316L	07

The regulating valve is for use where precise flow adjustment is required.

90 Degree (angle pattern) strainer

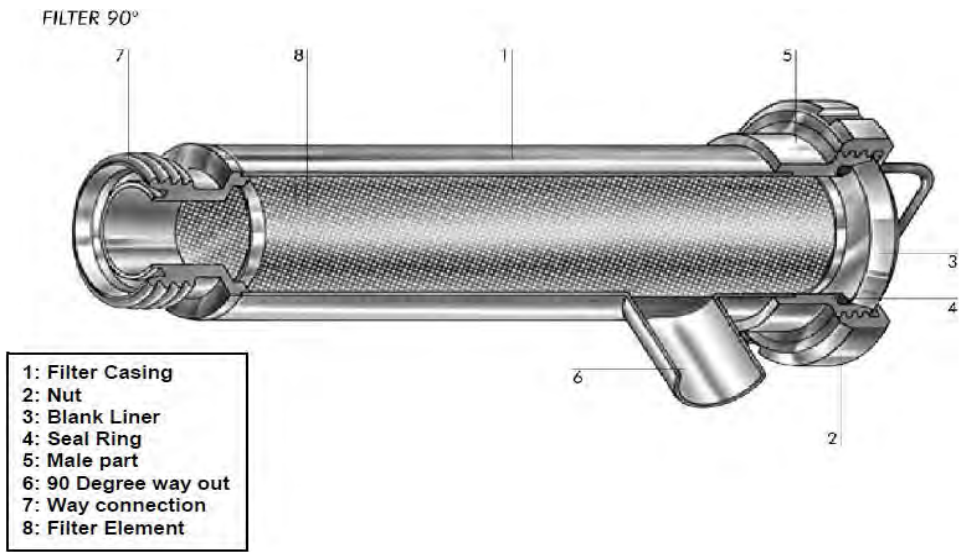

The filter element mesh is available in a variety of hole sizes 0.25mm, 0.5mm, 1mm, 1.5mm, 2mm, 3mm. Please enquire if your preferred size is not listed.

The filter body (like the element) is manufactured from Grade 316 stainless steel and is supplied as standard with plain ends to allow for welding of your preferred connection type.

More information on following page.

Y Strainers, In-line filter and Duplex Strainers

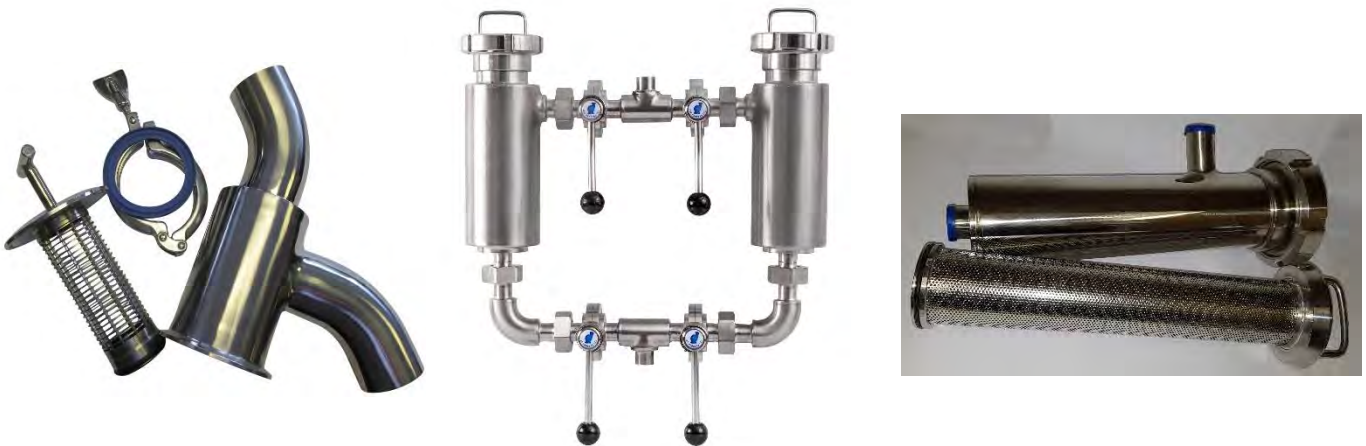

For more information contact 0113 252 6712

Art 95 / A

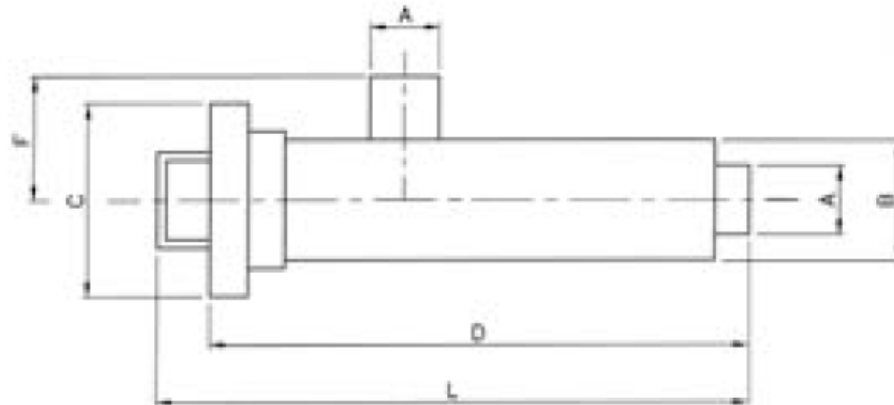

INCH	DIN	A	B	C	D	E	F	L
1"		25 , 4	70	112	311	211	75	358
	25	28	70	112	311	211	75	358
	32	34	70	112	311	211	75	358
1 ½"		38 , 1	70	112	311	211	75	358
	40	40	70	112	311	211	75	358
2"		50 , 8	70	112	311	211	75	358
	50	52	70	112	311	211	71	358
2 ½"		63 , 5	114 , 3	148	351	238	106	398
	65	70	114 , 3	148	351	238	117	398
3"		76 , 2	114 , 3	148	351	238	112	398
	80	85	129	148	351	238	106	404
4"		101 , 6	139 , 7	178	434	310	132	485
	100	104	139 , 7	178	434	310	120	485

180 Degree strainer

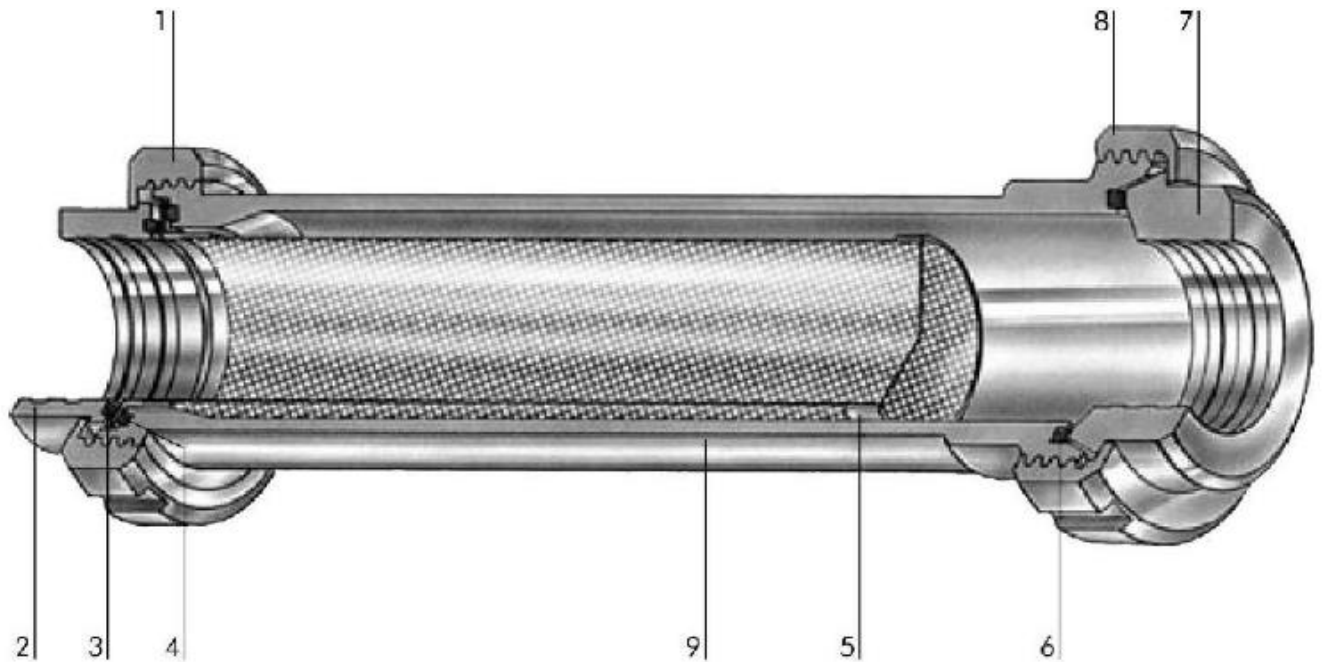

- 1] Nut
- 2] Way Connection
- 3] Seal Ring
- 4] Seal Ring
- 5] Strainer Element
- 6] Seal Ring
- 7] Way Out
- 8] Nut
- 9] Filter casing

180-degree strainer.
Manufactured from Grade 316 stainless steel.
Mesh sizes available 0.25mm, 0.5mm, 1mm, 1.5mm, 2mm and 3mm.
Other mesh sizes are available on request.

Versaline pressure relief valve (VPRP type)

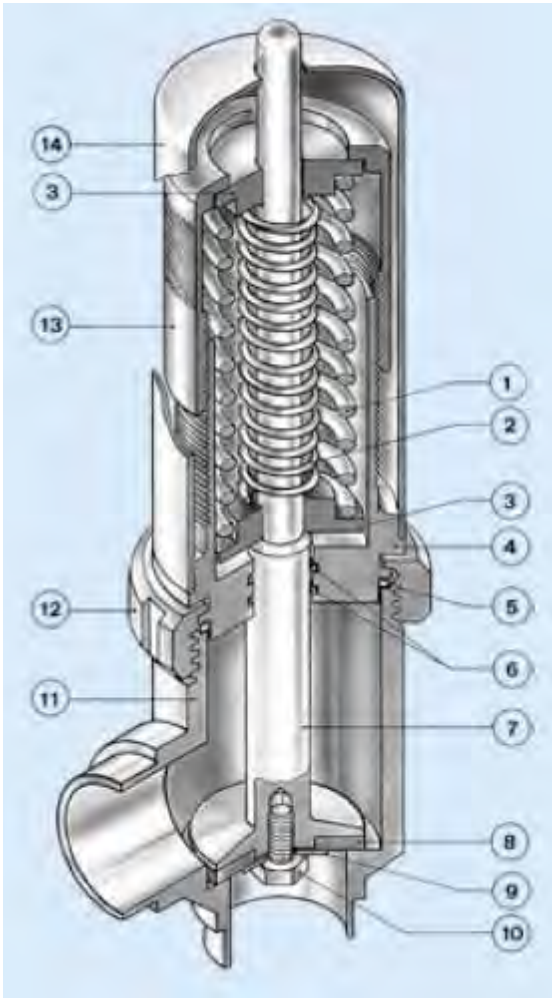

PART	MAT	DESCRIPTION
1	Aisi 302	Big Spring
2	Aisi 302	Small Spring
3	Bronzo	Spring Seat
4	Aisi 304/316	Casing
5	Vitton , NBR	O-Ring
6	Vitton , NBR	O-Ring
7	Aisi 304 / 316	Pin
8	PTFE / Vitton / EPDM	Seal Ring
9	Aisi 304 / 316	Washer
10	Aisi 304 / 316	Nut
11	Aisi 304 / 316	Casing
12	Aisi 304	Nut
13	Bronzo	Adjusting Screw
14	Aisi 304	Cover

Used to protect pumps and tanks etc from over pressurisation. Available up to 10 Bar.

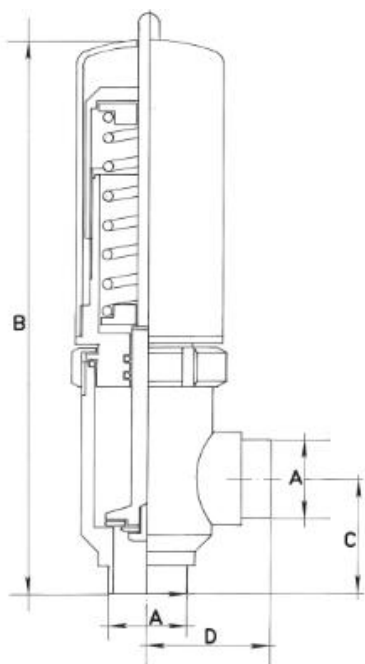

CODE	SIZE (INCH)	A	B	C	D
VPRP10V/91	1"	25 , 4	284	50	56
VPRP15V/91	1 1/2"	38 , 1	304	60	62
VPRP20V/091	2"	50 , 8	314	65	69
VPRP25V/091	2 1/2"	63 , 5	320	70	88
VPRP30/091	3"	76 , 2	320	70	88

PEMS IV sample valve



Applications:

The PEMS IV sampling valve is used to take a liquid sample from a process line or a tank for quality and/or bacteriology controls.

Its hygienic ‘flush membrane’ hygienic design (flared body) guarantees the absence of retention zones (favourable to bacterial growth) with clear and/or relatively non-viscous liquids, as well as excellent cleanability. Its opening system closes the valve once the sample has been taken. Forced opening enables product flow to be controlled and to keep sampling open in CIP/SIP phases.

Operating conditions:

The standard versions of the PEMS IV sampling valve are as the sizes shown in the dimension chart in this datasheet. The standard version is supplied with a smooth weldable sampling inlet and outlet. It can be flame sterilised and has the possibility of cleaning circulating CIP or SIP products (see ordering information below).

The opening and closing with the handle can be carried out in two ways, either by pushing (which enables self-closing) or raising the handle (which enables sampling to be continuous). The DN6 and DN10 working pressures are respectively 6 and 5 bar and the working temperature is 120°C. Food grade seals are used throughout.

Ordering information:

2 spout version is used to circulate a CIP or SIP product in the valve body without contacting the process line. Silicon plugs are used to keep alcohol in the body of the valve between sampling operations.

Connections to spout(s):

- Male 0.5” , 1/4” , or 3/8” left handed thread
- Clamp, mini clamp or micro clamp
- Fluted

ATEX version (on automatic valve)

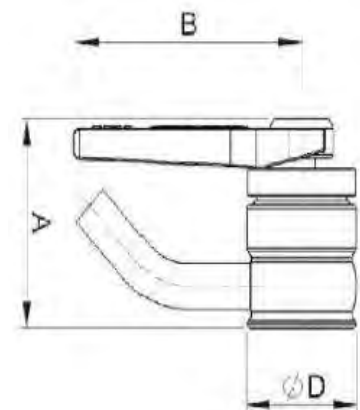

Ø D	A	B	C
DN6	51	56	24.5
DN10	5	76	34.5

PEMS simplified sampling valve with membrane



The PEMS sampling valve is used to take a sample of clear or low viscosity liquid from a process line or tank in order to carry out quality and/or bacterial controls. Valve sealing is obtained by a membrane. The hygienic design guarantees there is no retention zone (an ideal place for bacteria to develop) and is easy to clean. Its hygienic qualities, as well as its easy assembly and maintenance, make it a reference on the market.

Key Benefits:

Hygienic design with flared body
 Low acquisition and usage costs
 Modular opening
 Easy to use and easy maintenance

Applications:

Sampling on the tank or transfer line of clear or low viscosity liquid (non-sticky, non sugary and non-solidifying)
 Equipment especially suited to sampling of products subject to quality and / or bacterial controls

Technical Specifications:

Size: DN6 and DN10
 Intake connection: To weld
 Outlet connection: Smooth
 CIP connection (optional): Smooth, Clamp
 Service pressure: From 0.1 to 6.0 bar
 Service temperature: from 0°C to 120°C
 CIP/SIP support: Up to a temperature of 130C for 20 to 30 minutes
 Materials:

- Parts in contact with the product: 1.4404 (316L) Stainless Steel
- Other parts: 0.4307 (304L) or 1.4404 (316L) Stainless Steel
- Sealing VMQ membrane (Silicone)

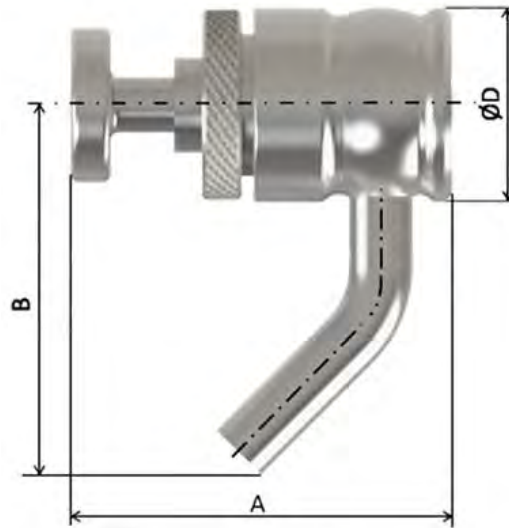

SIZES	A	B	D
DN6	49	52	24.5
DN10	70	57	34.5

Options

Additional intake for passage CIP liquid

VMQ (Silicone) or stainless steel cap(s)

Other intake connections: smooth nozzle to weld, micro clamp, clamp, female /male (DIN/SMS), thread 1/4, 3/8, 1/2

Other outlet connections: micro clamp, thread 1/4, 3/8, 1/2 ..

Other membranes: EPDM , NBR, Viton, FFKM

Membrane USP Class VI compliant

Aseptic Sampling Valve

To focus on optimising product costs, quality control and environmental standards.

We offer solutions for reducing effluent, optimising line cleaning, making processes secure and increasing the versatility of production lines.

Quality is an imperative. It is ensured by sampling, performed at the various stages of manufacture.

- Securing the samples
- Flush construction without retention
- Can be integrated into the cleaning cycles of the piping or tank
- Simple automation
- Easy use, maintenance and upgrading
- Low maintenance cost



Aseptic sampling valves
REC/RES/REM

Technical definition



Membranes identification:



Sterilization procedures:

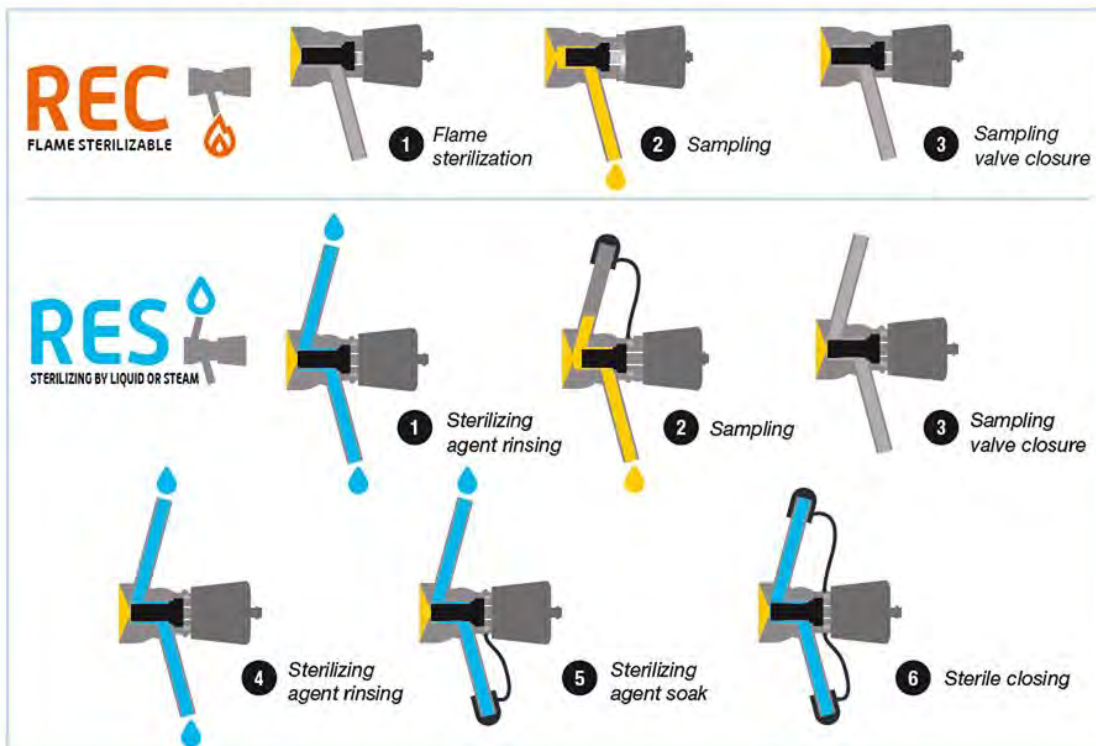

Technical characteristics:

ND	6	10	15
Service pressure*	0 to 10 bars	0 to 10 bars	0 to 10 bars
Operating temperature**	Stainless Steel pusher		DELFIN pusher/Pneumatic actuator
SILICONE	0°C to 200 °C		0°C to 110°C
EPDM	0°C to 120°C		0°C to 110°C
FKM	0°C to 200°C		0°C to 110°C
PTFE	0°C to 120°C		0°C to 110°C
Maximum sterilization temperature**			
SILICONE	149°C		110°C
EPDM	120°C		110°C
FKM	121°C		110°C
PTFE	120°C		110°C
Viscosity max. for a flow rate of 10 ml/s under 0.1b	200 cPo	1500 cPo	9000 cPo
Maximum particle size	0.8	1.3	2.2
Washing flow rate (m³/h) at speed of 3.5 m.s	0.2	0.6	1.5

*Internal service pressure (tank and / or pipe).

**Subject to chemical compatibility with the products in contact and fluid in the liquid state.

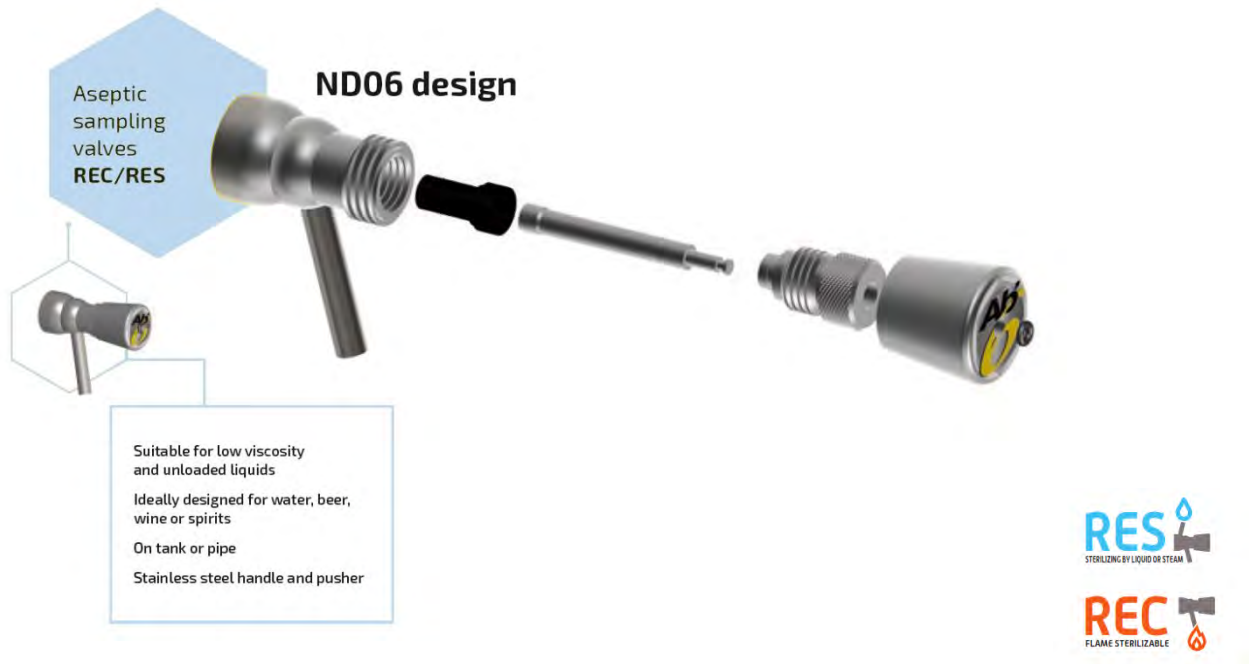

Standard construction:

EPDM, Silicone or FKM membrane
 Sterilisation inlet by tube nozzle
 Sampling outlet by tube nozzle

On request:

PTFE membrane construction
 Stainless steel body low ferrite 1.4435, Hastelloy or Alloy Uranus B6
 Inlet tube for sterilisation inlet and sampling outlet with specific connection (Clamp, SMS, DIN, thread etc)

Without retention area:

In the closed position, compressed by the mechanical action of the pusher, the membrane fills the passage orifice entirely by its deformation.

In the open position: compressed by the mechanical action of the gland, the membrane is perfectly flush with the sample tube.

Securing the operations: The thread of the gland is dissociated from that of the handle. There is thus no risk of loosening one by the action of the other.

Simplified automatisaton: The motorisation is done by a simple replacement of the pusher and the handle.

As an alternative to the manual construction, this valve can be equipped with:



Pneumatic actuator normally closed



Pneumatic actuator normally opened



Pneumatic actuator normally closed with detection



Pneumatic actuator normally closed with mixed control



Sampling valve closed by spring operation

Connection to tank or pipe:

	Flush membrane	Non-flush membrane
To be welded on tank wall	●	
Half clamp External Ø 50.5 mm	●	
BSP thread end 1/2" (15x21)	●	
Butt welded		●
Welded on tube to be welded on pipe	●	
Half micro clamp External Ø25 mm		●
BSP thread end 1/4" (8x13)		●
BSP thread end 3/8" (12x17)		●
Nutt ND25 SMS connection		●

● On stock ● Frequent stock ● Manufacturing

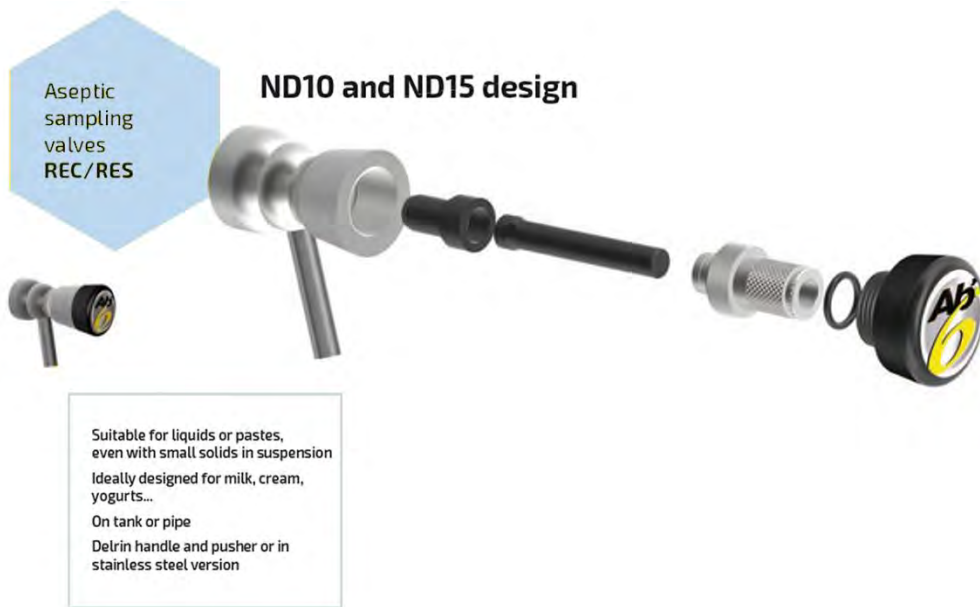

Standard construction:

EPDM, Silicone or FKM membrane
Sterilisation inlet by tube nozzle
Sampling outlet by tube nozzle

On request:

PTFE membrane construction
Stainless steel body low ferrite 1.4435, Hastelloy or Alloy Uranus B6
Inlet tube for sterilisation inlet and sampling outlet with specific connection (Clamp, SMS, DIN, thread etc)

Without retention area:

In the closed position, compressed by the mechanical action of the pusher, the membrane fills the passage orifice entirely by its deformation.

In the open position: compressed by the mechanical action of the gland, the membrane is perfectly flush with the sample tube.

Securing the operations: The thread of the gland is dissociated from that of the handle. There is thus no risk of loosening one by the action of the other.

Simplified automation: The motorisation is done by a simple replacement of the pusher and the handle.

As an alternative to the manual construction, this valve can be equipped with:

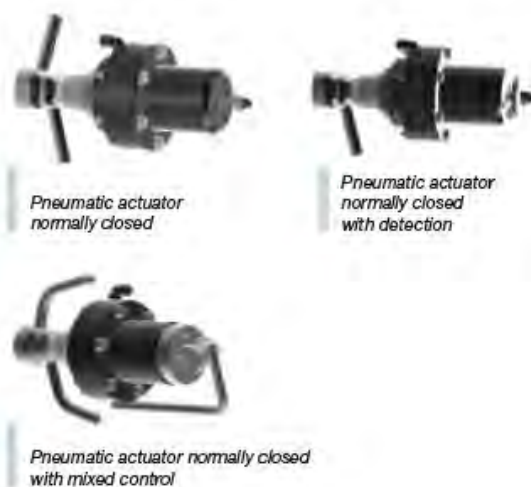

Connection to tank or pipe:

	Flush membrane	Non-flush membrane
To be welded on tank wall	●	
Half clamp External Ø 50.5 mm	●	
Welded on tube to be welded on pipe	●	
Butt welded		●
BSP thread end 1/2" (15x21)		●
Nutt ND25 SMS connection		●
NA CONNECT / INGOLD		●

● On stock

● Manufacturing

Aseptic Sampling Valve REM



On request:

Stainless Steel body low ferrite 1.4435, Hastelloy or Alloy, Uranus B6
Recording device

No bacteriological risk:

The elastomer membrane is positioned perfectly flush. A stainless-steel grid, placed on the front panel of the equipment, doubled by a PTFE membrane, makes it possible to differentiate the areas already used from those still available.

Excellent cleanability:

By the mechanical action of the gland, the membrane fills its body perfectly by its deformation.

Simplicity of maintenance:

The membrane and the PTFE control diaphragm are the only spare parts. Its maintenance does not require any specific tooling.

Connection to tank or pipe:

	40 holes	76 holes
To be welded on tank wall	●	●
Half clamp ¾" Øext 50.5 mm	●	●
Welded on tube to be welded on pipe	●	●
Butt welded	●	●
NA CONNECT / INGOLD	●	●

● On stock ● Frequent stock ● Manufacturing

Technical characteristics:

Holes	40	76
Service pressure*	-1 to 10 bars	0 to 10 bar
Operating temperature**	0 °C to 200 °	
SILICONE		
Perforation pressure	0 to 3 bars	0 to 3 bars
Maximum size of syringes (mm)	1.3	1.3

*Internal service pressure (tank and / or pipe)

**Subject to chemical compatibility with the products in contact and fluid in the liquid state

Evoguard Range Sampling Valve

Technical details

- Operating variants: Pneumatic actuator, lever automatically closing, hand wheel for fine adjustment
- Seal: Bellow PTFE-TFM 1705
- Monitoring: 'optional' via Initiator

Customer benefits

- Standard connection for welding
- Standard connection In-line: rotatable frame
- Resistant to all products and cleaning media
- Optimal cleaning conditions
- No dead space



Variants

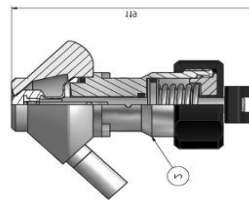

Tank Connection

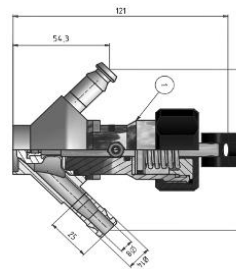
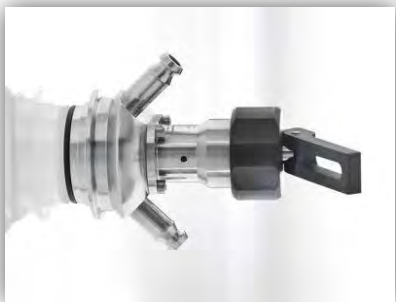

Welding end

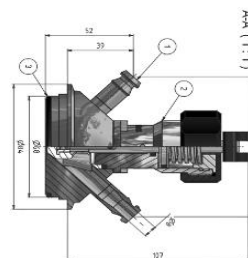

In Line

Evoguard Range Sampling System

Technical details

Operation:

Lever, automatically closing

Hand wheel for fine adjustment

Seal:

Bellow: PTFE-TFM 1705

O-Ring: RPDM /FDA

Sampling bottle: NALGENE

PN: 6 Bar

Filling and CIP – Valve closes up to 87 psi (6 Bar)

Customer benefits

Safe sampling

Protection: Overflow valve is opening from 6 psi (0.4 Bar) to 11 psi (0.8 Bar)



Description of function:



Cleaning



Mounting



Autoclave

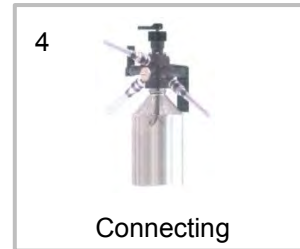

Connecting



Sterilisation



Sampling



Safety



Dismounting

Safety Valve



The process and rate of manufacture can evolve, in its entirety or in part, without changing the preparation, transfer and storage equipment. To maintain the sterility or safety of their contents, tanks cannot be directly connected to the atmosphere.

Being subject to variations in level during the filling, emptying and washing phases, they must therefore be equipped with breather valves.

- Tank safety during CIP, SIP
- Pressure/ Vacuum
- Construction suitable for thermal shocks
- Open or collectable exhaust
- Possibility of opening detection, cleaning at the valves, heating, anti-insect grill
- Minimum calibration of -1 mb and +30 mb
- DN50 to 300
- Assembly delivered tested and proven, with calibration certificate

- Wide fit cross-section and performance guarantee
- Ease of installation
- Ability to develop the construction
- Low maintenance frequency
- Ease of cleaning

See also:

Tank vents P110

Tank safety units P149

BOGV pressure & vacuum safety valve

The BOGV valve is intended to protect inerted storage tanks, more especially in the wine producing domain, against vacuums (vacuum breaker) and excess pressures.

Key Benefits

- Combined pressure and vacuum valve
- Specially designed for storage tanks in protected atmospheres
- Fully autonomous (no external control required for its operation)
- Simplified and cost-effective maintenance
- Low pressure sealing (regulation of the gas stratification and control of the nitrogen consumption)
- The best quality/price ratio on the market

Applications

- Storage of food and non-food products and more especially wines and champagnes
- Tanks where the inerting value is between 15 and 35 m bars and where the service temperature does not exceed 40C
- Exclusively designed to transport gases (in case of overflow, the valve elements must be dismantled and cleaned manually)

Technical Specifications

Sizes: DN50

Tank Connection: Straight vertical clamp SMS 76

Pressure setting by weight in Stainless Steel: 40mbar

Vacuum-relief setting by VMQ membrane (Silicone): -1 mbar

Maximum pressure in the tank: 80 mbar

Tank fill rate: Up to 100m³/h (pressure in the tank below 80mbar)

Tank draw-off rate: up to 100m³/h (vacuum in the tank between 0 and -5 mbar)

Service temperature: +5°C to 40°C

Washing temperature: +85C maximum (in natural cooling conditions and with no thermal shocks)



Materials:

- Parts in contact with the product: 1,4404, (316L) stainless steel
- Other parts: 1.4307 (304L) Stainless steel
- Sealing EPDM and silicone gaskets

SIZES	A	B	D
DN50	124	176	91

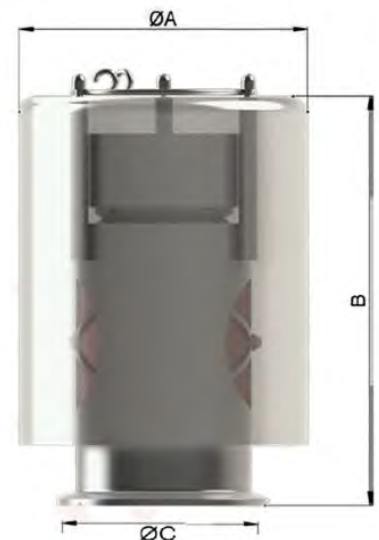

BOG pressure, vacuum-relief & gas collection safety valve

Bog safety valves are intended to protect low pressure tanks not covered by PED against vacuums (vacuum breaker) and/or excess pressure. Depending on the version, the valve blow-off can be collected. We have design tools to dimension a valve with respect to tank characteristics (diameter and height), Resistance (pressure, vacuum) and washing conditions (temperature, flow-rate).

Key benefits

- Fully autonomous (no external control required for its operation)
- Different models available according to requirements: Pressure/vacuum (with or without blow-off collection), Pressure only (with or with-out blow-off collection), vacuum only
- Safety valves compatible with hot / cold washing (after validation by the validation tool)
- Simplified and cost-effective maintenance
- Low pressure sealing
- Hygienic design
- Freeze protection option available on request

Applications

- Manufacture and storage of foods and non-foods products in a controlled atmosphere (dairy products, beverages, waters, creams and other cosmetic products, fine chemicals, etc)
- Tanks not covered by PED, where the service pressure is less than 0.5 bar and the service temperature is less than 120°C
- Exclusively designed to transport gasses

Technical specifications

Size: DN40, DN65, DN100, DN150 compliant with most connection standards (DIN, SMS, OD, ISO)

Tank Connection: Smooth weld end, male, female, clamp, flange

Washing nozzle connection (option): Mini-Clamp

Weight pressure calibration: 2 to 50 mbar

Pressure calibration with spring: 50 to 490 mbar

Weight vacuum calibration: -2 to -50 mbar

Vacuum calibration with spring: from -50mbar

Temperature: +1°C to 120°C

Inside surface state: Ra 0.8 µm

Materials:

- Parts in contact with the product: 1.4404 (316L) stainless steel
- Non-return valves: PTFE or 1.4404 (316L) stainless steel as per calibration
- Other parts: 1.4307 (304L) stainless steel
- Sealing: EPDM seals



Options:

- Compliant ATEX 2014/34/UE, Zones 1 &2, gas & dust (Models with blow-off collection)
- Compliant PED (Vacuum Valve)
- Drip collector and anti-insect filter on the vacuum part
- Washing nozzle (the drip collector and anti-insect filter are highly recommended)
- Sterile air intake on elbow-joint enabling all inerting and protection functions to be included on a single tank spigot
- Inductive opening detection in vacuum
- Protection against freezing by a temperature probe, heater cable and thermostat, to ensure valve operation at outdoor temperatures lower than 0°C
- Specific surface state on request (inside and/or outside)
- Other gaskets (specific service conditions) Viton, silicone, nitrile rubber

Dimensions in mm (approximate values only)

Pressure & Vacuum valve:

BOG A SIZE	DN40		DIN65		DIN100	DIN150
	SMS	DIN	SMS	DIN	SMS	DIN
C	110	110	152	177	197	392
D	120	120	162	162	325	325
E	204	204	240	240	311	357
F	225	237	303	312	385	493
G	21	33	62	72	74	136
∅	38*1.25	41*1.5	63.5*1.6	70*2	104*2	154*2

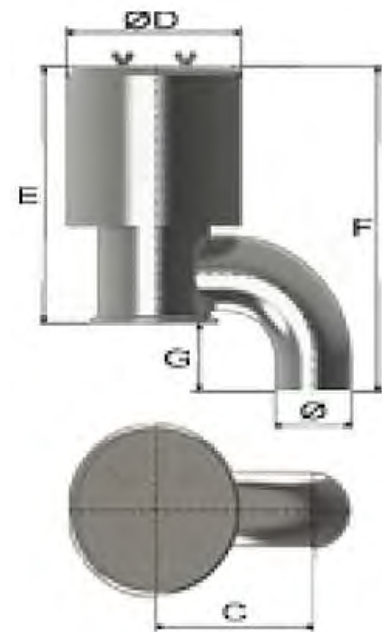

Pressure, Vacuum valve, collected pressure:

BOG A SIZE	DN40		DIN65		DIN100	DIN150
	SMS	DIN	SMS	DIN	SMS	DIN
C	110	110	152	177	197	392
D	102	102	132	132	196	284
E	204	204	235	235	360	476
F	21	33	62	72	74	136
G	58	69	82	102	112	167
H	151	162	219	229	313	453
∅	38*1.25	41*1.5	63.5*1.6	70*2	104*2	154*2

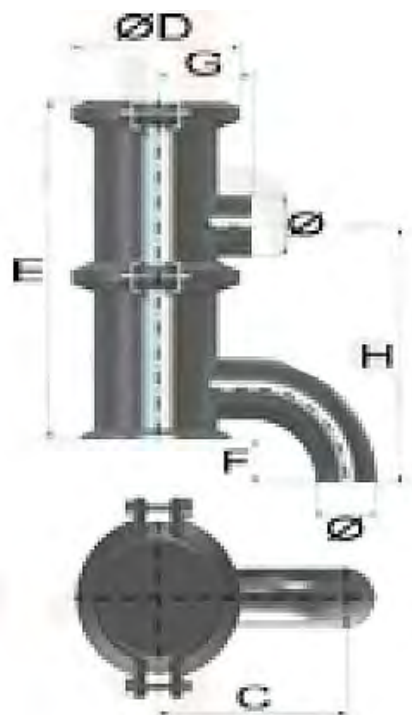

Pressure Valve:

BOG A SIZE	DN40		DIN65		DIN100	DIN150
	SMS	DIN	SMS	DIN	SMS	DIN
D	120	120	162	162	325	325
E	125	131	180	180	325	264
∅	38*1.25	41*1.5	63.5*1.6	70*2	104*2	154*2

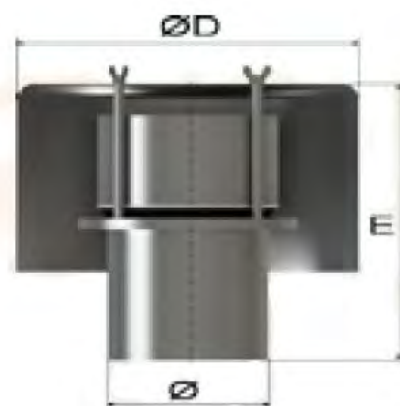

Collected pressure valve:

BOG A SIZE	DN40		DIN65		DIN100	DIN150
	SMS	DIN	SMS	DIN	SMS	DIN
D	102	102	132	132	196	284
E	108	108	123	123	188	248
F	23	23	25	25	25	12
G	58	69	82	102	112	167
H	54	57	68	71	91	101
∅	38*1.25	41*1.5	63.5*1.6	70*2	104*2	154*2

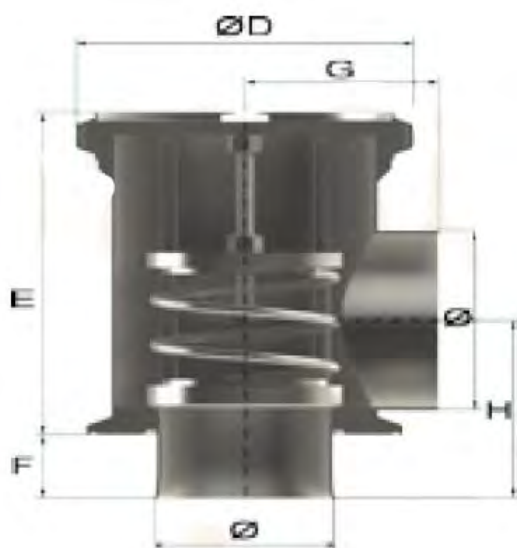

Vacuum Valve:

BOG A SIZE	DN40		DN65		DIN100	DIN150
	SMS	DIN	SMS	DIN	SMS	DIN
C	110	110	152	177	197	392
D	102	102	132	132	196	284
E	108	108	123	123	188	248
F	21	33	62	72	74	136
∅	38*1.25	41*1.5	63.5*1.6	70*2	104*2	154*2

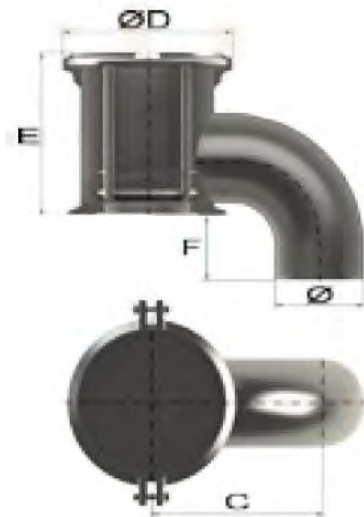

HSV-A pressure, vacuum relief & thermal shock safety valve 3-A

The valves in the HSV range are hygienic equipment intended to protect tanks against vacuums (vacuum breaker) and/or excess pressure. They are fitted with a technical tube (washing function, sterile air intake). The pressurised function blow-off is collected. The passage sections, different for pressure and vacuum, are specifically designed to protect the tanks against sudden temperature variations resulting from hot washing (and SIP) followed by a cold rinse.

Key Benefits:

Valve certified 3-A 50-01

- Combined pressure and vacuum
- Specifically designed for protection against thermal shocks (hot/cold washes)
- Fully autonomous (no external control required for its operation)
- Hygienic design
- Simplified and cost-effective maintenance (with no lifting or special tools)
- Numerous options available according to requirements

Applications:

- Tanks not subject to PED compliance where the service pressure is less than 0.5 bar
- Tanks subject to PED compliance where the service pressure is more than 0.5 bar (special version available on option)
- Tanks where the service temperature does not exceed 120°C
- Exclusively designed to transport gases

Technical specification:

Drip collector and anti-insect filter in vacuum

Sizes: DN100/65, DN150/100, DN250/150, DN320/150 and DIN 450/150

Connection on the tank by 90° elbow joint: To weld male, female, clamp, flange

Pressure setting: 50 to 500 mbar (non-PED) or in PED version according to size

Vacuum-relief setting: -5 mbar

Service temperature: +10°C to 140°C

Internal washing tube orientation 180° (opposite the elbow joint)

Blow-off collection (pressurised): to weld

Materials:

- Parts in contact with the product 1.4307 (304L) Stainless Steel
- Non-return pressure valve 1.4404 (316L) Stainless Steel
- Non-return vacuum valve: 1.4404 (316L) Stainless Steel
- Sealing: EPDM gaskets

Inside surface state: Ra 0.8 µm



Dimensions in mm:

(The first diameter corresponds to the vacuum function, the second to the pressure function)

SIZES	A	B	C	D	E
DN100/65	104*2	70*2	440	136	351
DN150/100	154*2	104*2	625	184	392
DN250/150	254*2	154*2	801	320	655
DN320/150	324*2	154*2	912	398	807
DN450/150	457*3	154*2	1116	547	1124

SIZES	F	G	H	I	PED Max Pressure Calibration
DN100/65	363	146	131	120	5
DN150/100	364	146	129	150	4
DN250/150	437	146	224	220	3
DN320/150	507	156	271	220	1.5
DN450/150	630	156	423	220	

Freeze protection option:

SIZES	Pressure function	Vacuum-relief function	Anti-snow system option (Vacuum)
DN100/65	-	-	-
DN150/100	2 x 500 W – 230 V	500 W – 230 V	-
DN250/150	2 x 600 W – 230 V	500 W – 230 V	450 W – 230 V
DN320/150	2 x 600 W – 230 V	1000 W- 230 V	450 W – 230 V
DN450/150	2 x 600 W – 230 V	1500 W – 230 V	-

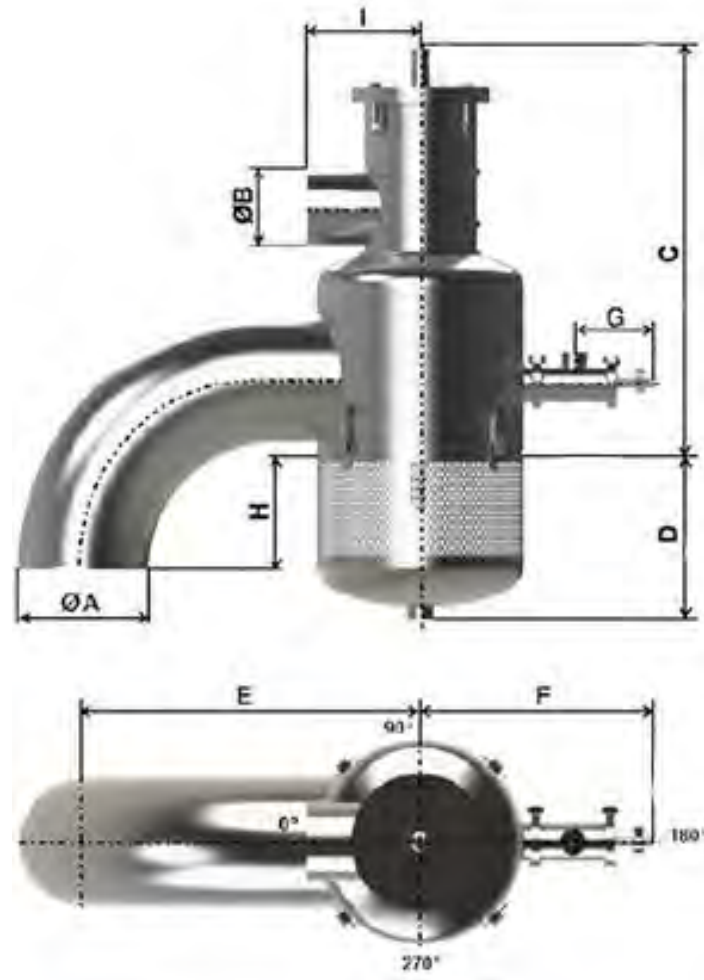

Evoguard Overflow Valve

A big topic in beverage production is flow control. Often it is necessary to keep the product pressure constant under different product removal out of the pipes. This is a special application for overflow valves. As soon as the product pressure exceeds, the pressure which is appointed, the valve opens into the bypass. This ensures cavitation demands at pumps and keeps the product pressure constant in the pipelines.

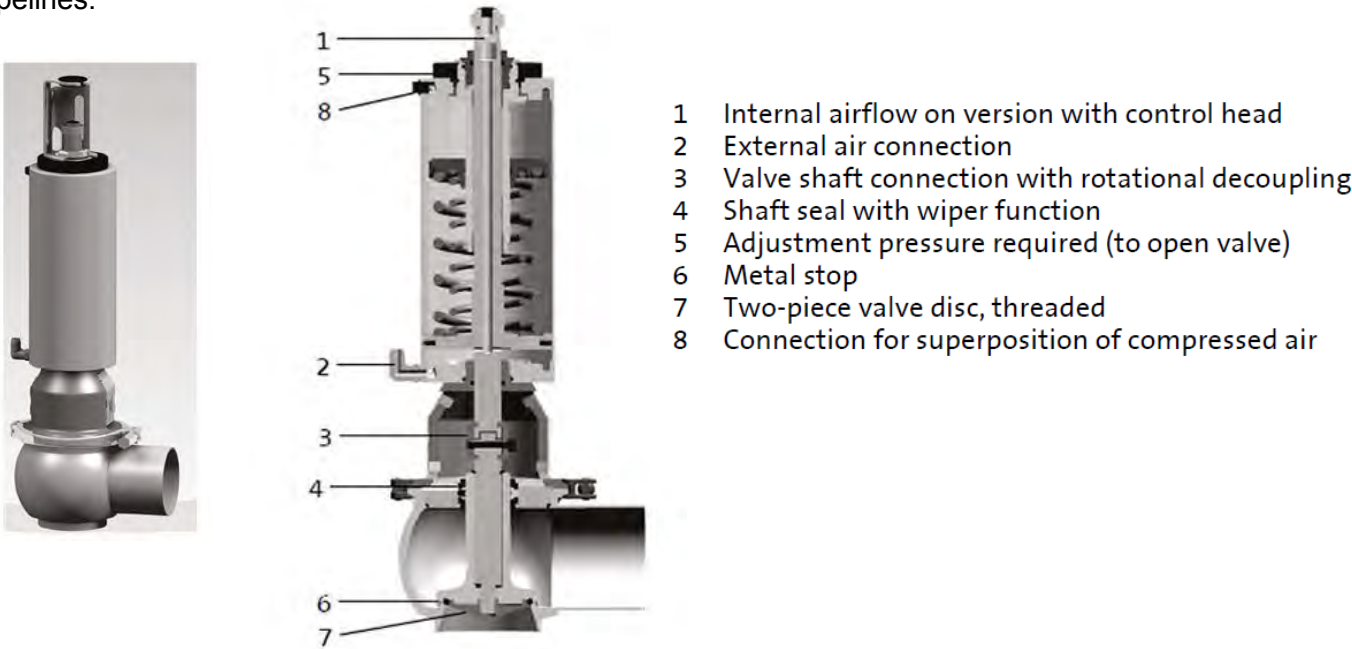

- 1 Internal airflow on version with control head
- 2 External air connection
- 3 Valve shaft connection with rotational decoupling
- 4 Shaft seal with wiper function
- 5 Adjustment pressure required (to open valve)
- 6 Metal stop
- 7 Two-piece valve disc, threaded
- 8 Connection for superposition of compressed air

Pressure setting

DN	Actuator D85/0-3		Actuator D85/1-9		Actuator D104/4-29		Actuator D129/21-41	
	min. bar	max. bar	min. bar	max. bar	min. bar	max. bar	min. bar	max. bar
25	2,2	10,0	-	-	-	-	-	-
40	0,6	3,0	1,8	8,0	5,6	10,0	-	-
50	0,6	3,0	1,8	8,0	5,6	10,0	-	-
65	0,3	1,5	0,8	4,1	2,6	10,0	-	-
80	-	-	0,4	2,4	1,3	7,4	5,7	10,0
100	-	-	0,2	1,5	0,7	4,8	3,5	6,7

Higher pressure available upon request!

TECHNICAL DATA

Pressures

Product pressure	Adjustable, please see table above) / vacuum -13,8 psi (-0,95 bar)
Housing	PN 360 psi (25 bar)
Control air pressure	min. 87psi (6 bar) - max. 115 psi (8 bar)

Material

With product contact	1.4404 / AISI 316L
Without product contact	1.4301
Seal	EPDM / FDA Other materials available upon request

Surface

With product contact	Ra ≤ 0.8 µm
Without product contact	Ra ≤ 1.6 µm

For Vacuum valve information see tank safety P143

Static spray ball



This datasheet refers to our range of static spray balls. Also available from us are rotating spray balls. Information on these is available on a separate datasheet, please do not hesitate to ask for one.

See following page for size and fittings chart.

Spray balls are manufactured in different sizes with options of connections and drilling patterns to suit various applications.

The flow rate required will depend on factors such as:

Duration of the cleaning cycle, type and temperature of the cleaning fluid, the nature of the vessel contents etc. Most industries have evolved their own cleaning procedures based on trial and experience with their own particular products, however as a general guide the flow rate required and hence the size or number of spray balls required can be determined as such:

For vertical tanks – Allow one cubic metre per hour for every metre of tank circumference.

For horizontal tanks – Allow one cubic metre per hour for 2 x diameters + 2 x length in metres.

The pressure of the cleaning fluid at the spray ball should be between one and three bar. Higher pressures can result in the fluid atomising and reducing the cleaning effect.

Static spray ball selection chart

PART NO	SPRAY HOLE DIA (MM)	BALL DIA D (MM)	CONNECTION SIZE & TYPE	H (MM)	FLOW (M ³)				CLEANING RADIUS			
					TYPE A	TYPE B	TYPE C	TYPE D	TYPE A	TYPE B	TYPE C	TYPE D
SB1	2.5	65	1" Clip	60	15.7	10.2	10.5	10.1	1.8	3.0	3.2	2.9
SB2	2.5	65	1.5" Clip	60	18.8	8.4	11.2	10.2	2.6	2.0	3.7	3.0
SB3	2.5	65	0.75" BSPF	45	13.2	8.7	9.2	9.2	1.3	2.2	2.5	2.5
SB4	1.6	50	1.5" Clip	53	6.6	4.0	3.7	3.9	1.9	2.8	2.3	2.6
SB6	2.5	65	1.25" Clip	59	17.9	9.3	10.5	10.1	2.3	2.5	3.2	3.0
SB7	2.5	65	1.5" Clip	60	18.3	8.1	11.8	10.4	3.0	2.4	4.9	3.9
SB8	1.6	50	0.75" Clip	49	5.5	3.4	3.2	3.5	2.5	3.8	3.4	4.1
SB9	1.6	50	0.5" BSPF	49	5.4	3.0	3.1	3.3	2.4	3.0	3.2	3.6
SB10	1.6	50	1" Clip	52	7.2	4.7	4.7	4.5	4.3	7.2	7.2	6.7
SB11	2.5	90	1.25" BSPF	63	29.3	12.7	15.9	15.9	3.1	2.2	3.4	3.1
SB12	2.5	90	1.5" Clip	75	24.2	13.4	15.9	14.2	2.0	2.4	3.4	2.8
SB14	2.0	120	2" Clip	87	19.0	10.2	8.9	10.0	2.0	2.3	1.7	2.2
SB15	1.6	40	0.75" Clip	44	3.7	2.3	2.3	2.4	3.8	5.5	5.9	6.1
SB16	1.3	40	0.75" Clip	44	5.1	3.0	3.1	3.1	4.7	6.4	7.0	7.1
SB17	1.3	28	0.25" BSPF	23	1.8	1.2	1.4	1.4	1.0	1.6	2.2	2.3

Please note that all values quoted in this table are at 1 bar working pressure

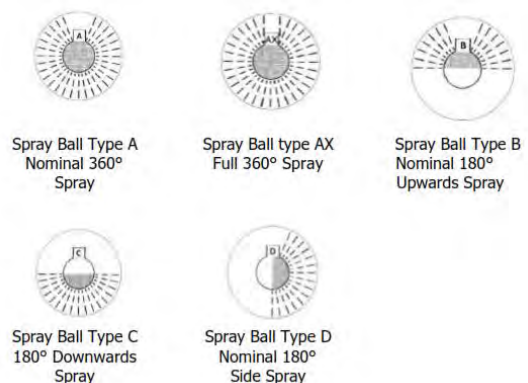
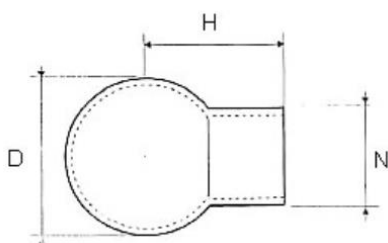

RSB type rotating spray ball

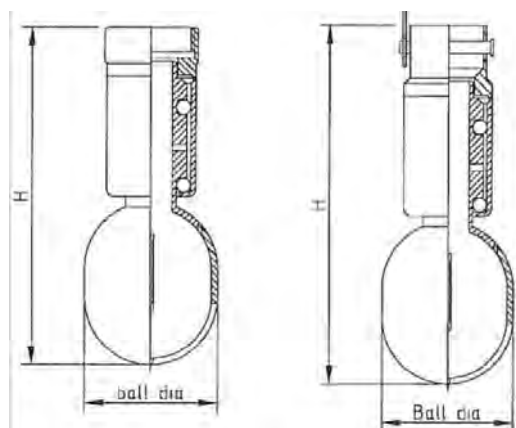

Pictured spray ball is the slip-on type. BSP connection is also available
Subject to modification without notice in advance.

Applications

Fluid driven rotating spray nozzles are ideal for use in tanks and vessels where a static spray ball is unable to clean sufficiently. The double bearing design ensures reliability and long service life.

They are available in slip on and BSP connection types. (See chart on previous page for application data).

The slip-on type come complete with a retaining pin/clip to eliminate any possible disconnection issues.

Operating Conditions

Designed to give excellent cleaning performance from relatively low (1 or 2 bar) fluid pressure.

Ordering Information

All available sizes and connection options are listed in the chart on the next page.

CODE	CONNECTION TYPE	SIZE	SPRAY DIAMETER (METERES)	FLOW RATE		BALL DIAMETER (MM)	H (MM)
		DIN11850/DIN11866/INCHES		(M ³ /H)	BAR		
DIN / ISO1127 / INCH							
SB45-360-05C/89	SLIP ON	12-13 / 13.5 / 0.5"	1.2 - 1.6	2.6	3.5	45	102
SB45-360-07C/89	SLIP ON	18-19 / 17.2-21.3 / 0.75"	1.8 - 2.0	4.1	5.5	45	115
SB45-360-02BSP/89	1/4" BSP	13 / 13.5 / 0.5"	1.2 - 1.6	2.6	3.5	45	102
SB45-360-05BSP/89	1/2" BSP	19 / 17.2-21.3 / 0.75"	1.8 - 2.0	4.1	5.5	45	115
SB45-360-10C/89	SLIP ON	28-29 / 26.9 / 1.0"	2.4 - 2.6	4.2	6.9	45	120
SB65-360-15C/89	SLIP ON	40-41 / 26.9 / 1"	3.5 - 4.0	11	15	65	150
SB45-360-07BSP/89	3/4" BSP	29 / 26.9 / 1"	2.4 - 2.6	4.2	5.9	45	120
SB65-360-15BSP/89	1.5" BSP	41 / 33.7 / 1.5"	3.5 - 4.0	11	15	65	150

Versaline rotating spray ball features & advantages

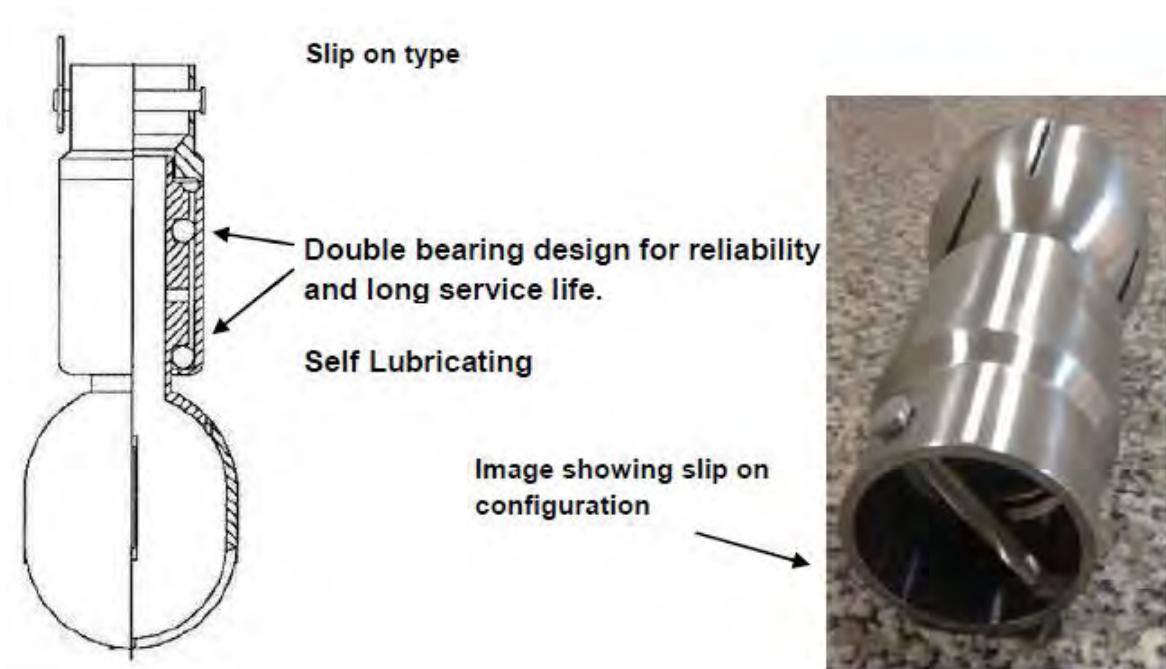

Subject to modification without notice in advance

Placement of Sprayball

Placement of Spray ball (with cleaning pressure at 2 Bar):

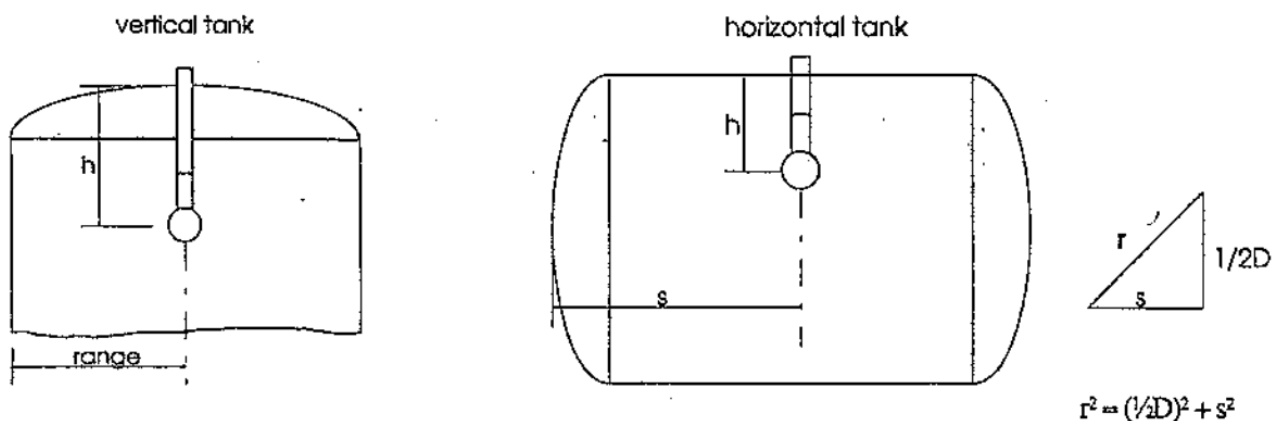

Things to consider when choosing cleaning device

Area in charts	Soilage level	Ability of cleaning liquid to remove product (soilage)	Tank Size (Ltr)			
			SB45		SB65	
			Horizontal	Vertical	Horizontal	Vertical
A	Light	Very easy (deluge)	<7.000	<12.000	<17.000	<60.000
B	Medium	Relatively easy	<6.000	<10.000	<13.000	<45.000
C	Heavy	Demands small impact	<2.000	<3.500	<3.500	<10.000

Versaline 360 Rotary Head Jet



Features

The injector is an advanced irrigation cleaner used in:

- Food and Drink
- Pharmaceutical
- Chemical treatment
- Transport
- Beverage

Advantages are:

- Self-cleaning
- Low liquid consumption
- Hygienic design
- Flush fitting

Typical application

- Fixed installation CIP system
- Process containers and reactors
- Store tank
- Transport tank equipment
- Fermentation
- Yeast breeding

Technical detail

- Flow: 4-4.5m³
- Inlet pressure: 4-10 Bar
- Suggested pressure: 6 Bar
- Max temperature: 95C
- Connection: BSP, 1.5" – DN 40/1" DN25
- Clamp DIN/INCH, 1.5" – DN40
- Material: 316L / 1,4404, PTFE
- Lubrication; cleaning medium

Versaline 360 rotary head jet payback

Versaline 360 rotary head jet	£1,800
Cleaning method	Water consumption
Spray ball	11000 Gallons/hr
Versaline 360 rotary jet head	3740 Gallons/hr
<u>Time to clean</u>	
Spray ball	45 mins = 8250 Gallons
Versaline 360 rotary jet head	30 mins = 1870 Gallons
<u>Cost per clean</u>	
Water per 220 Gallons	£1.00
Effluent per 220 Gallons	£2.00
Heat per 220 Gallons	£4.00
Total	£7.00
Spray ball [8250 gallons / 220 gallons of water = 37.50*£7.00]	£262.50
Versaline 360 rotary jet head [1870 gallons / 220 gallons = 8.5*£7.00]	£59.50
Saving	£203.00
Payback	8.25 washes

Operation:

*Operating parameters of Jet heads: 17m³/hr at 6 Bar

Key Benefits

Fully indexed high impact wash

Faster wash than spray ball due to greater efficiency

*System pipework, unions, valves, etc can be of smaller diameter

*CIP tanks can be of much smaller size due to less water in circulation

*These factors have not been taken into account in the calculations. If they were the extra cost for the rotary jet head would be recovered before the first clean.

Performance Curves

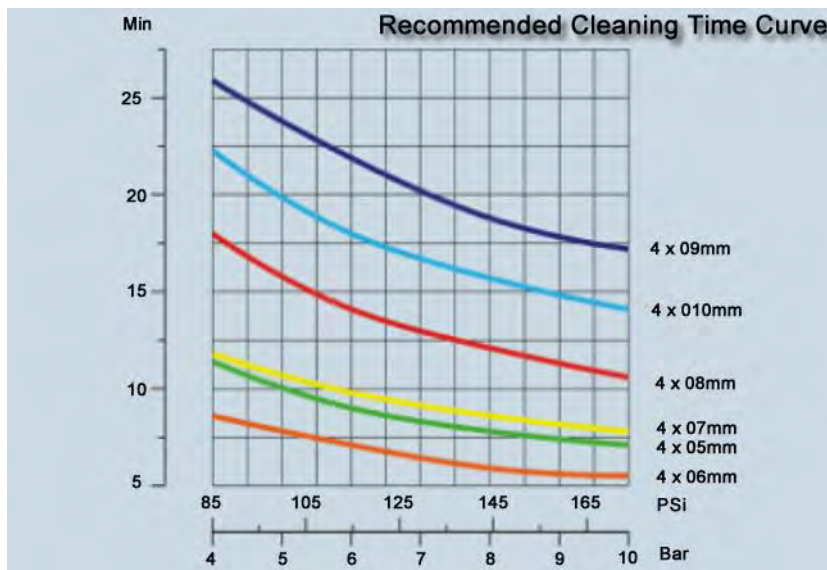
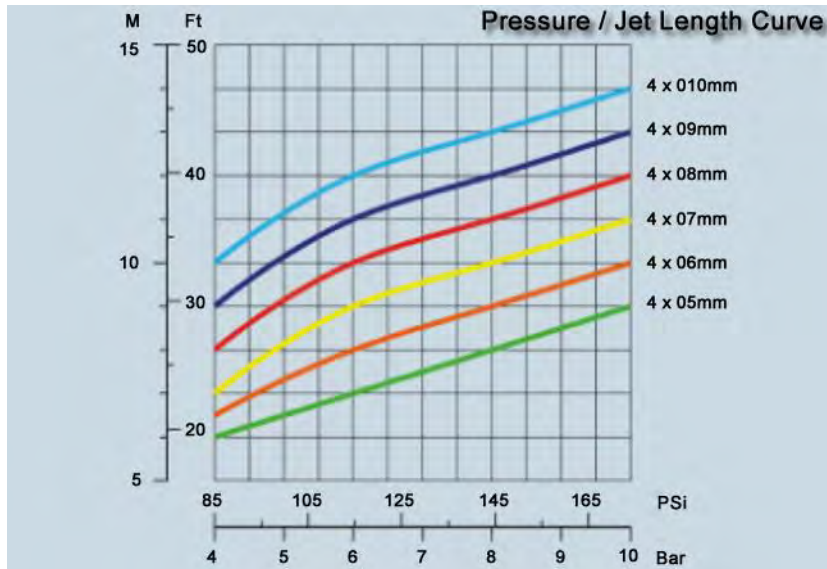
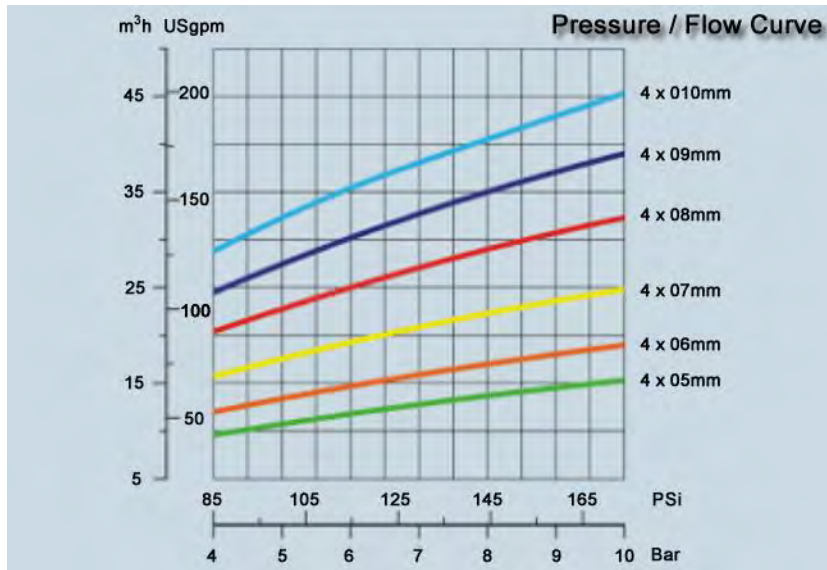

Specification

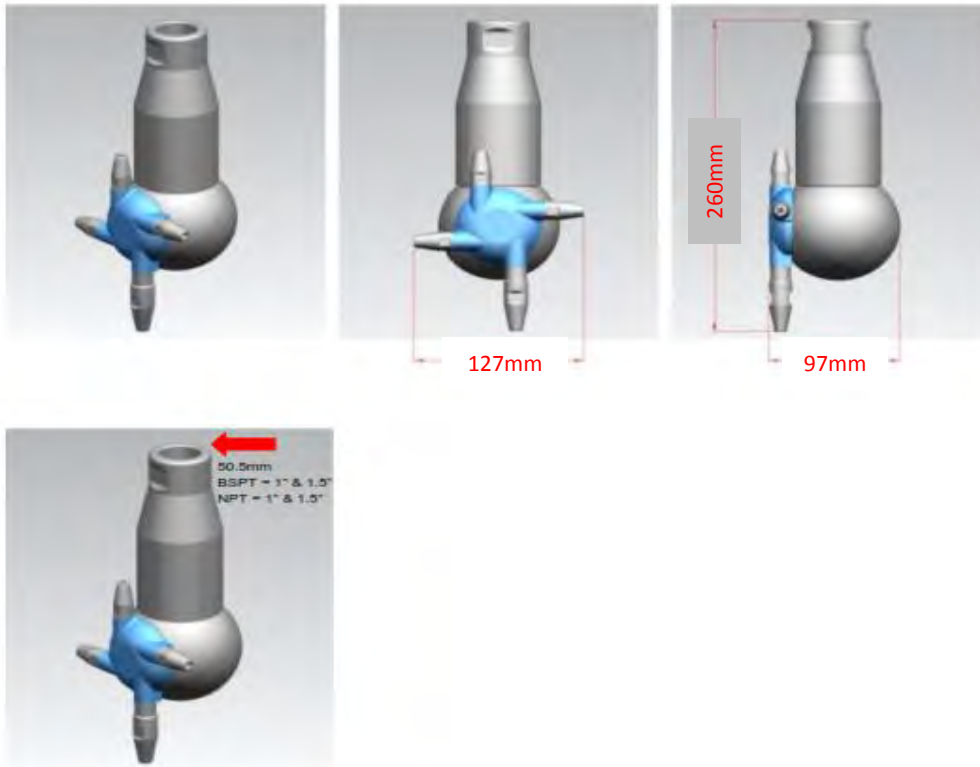

SGT type weld Sightglass DIN8902

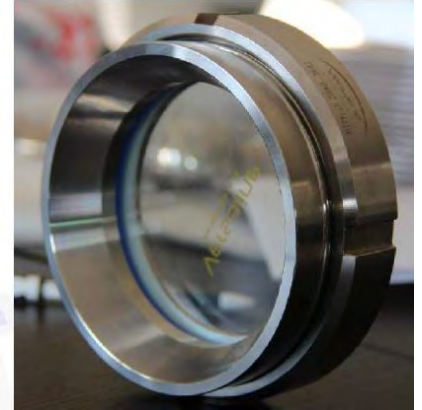
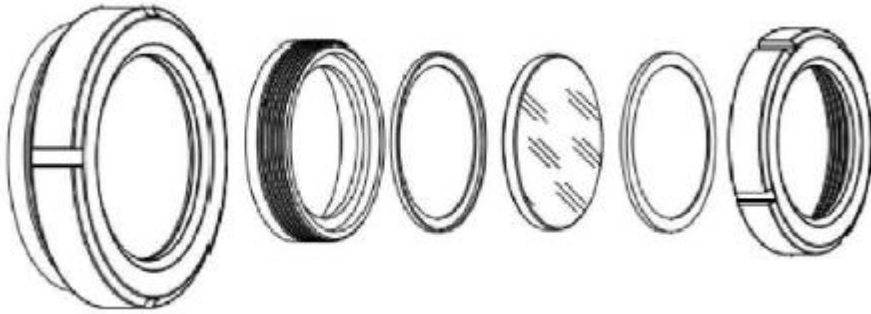

Applications

The compact design of this unit makes it ideal for inspection use in small Bio- reactor vessels and the lids of Manways or inspection hatches. Used widely in the food, dairy, beverage, cosmetic and pharmaceutical industries.

Operating Conditions

These units are available for pressures up to 10 BAR (depending on size, higher pressure ratings are available on request.)

Parts List

- 1: Welding male (1.43041/1.4404 material)
- 2: Nut (1.4301 material)
- 3: Gasket Silicon Max Temp 200°C
- 4: Sight glass disc (Borosilicate) Max temp 260 °C

Working pressure 10 bar

Certificates: EN10204.3.1 certificate
 Subject to modification without notice in advance
 Light fittings available upon request.

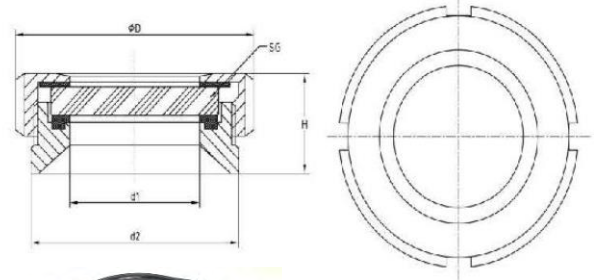

Light fittings for sight glasses



CODE	D1 (MM)	D2 (MM)	SG (MM)	D (MM)	H (MM)	P.R (BAR)
SGT50DPB/89	50	80 X 3	64.5 X 10	92	35	10
SGT60DPB/89	65	95 X 3	85 X 10	108	39	10
SGT80DPB/89	80	114 X 3	100 X 10	125	42	10
SGT100DPB/89	100	130 X 5	115 X 10	146	45	10

Standard Size *At temperature 50°C / 122°F
 *1 Bar = 14.5PSI = 0.1MPA
 DIN8902

SGT type sightglass self draining design neck ring comparison



Standard straight edged design is a liquid trap when sight-glass is fitted to the side of a vessel.

Standard type design

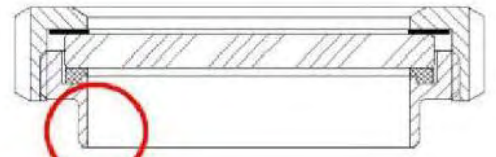

The Versaline design eliminates the possibility of liquid build up due to its self draining capability.

Versaline type design



Versaline Sightglass DIN28120



Application

Weld-on sight glass fittings for the observation of the internals of pressure vessels, silos, gear-trains, separators, pipelines etc.

Operating Conditions

These fittings are available for pressure up to 16 Bar (depending on size, higher pressure rating on request). For temperature rating (depending on material selection) see the following diagram.

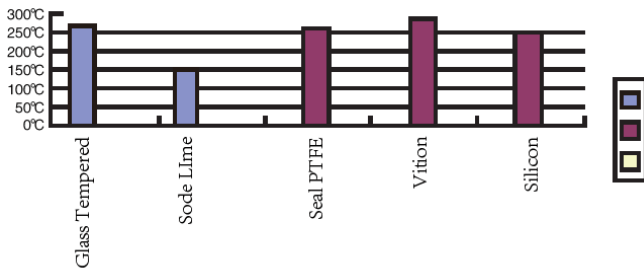

Ordering Information:

Please specify the selected items as follows:
 Fittings: nominal bore (DN) and nominal pressure (PN).
 Material: welding flange, bolts, cover flange, glass disc, seals.
 Light fittings available upon request.

Assembly

After welding base flange (1) onto or into vessel wall, seals (3), glass disc (4) and cover flange (5) are placed together in the order shown. Then the nuts (5) (in case of studed base flange) and washers are progressively tightened, always working on diametrically opposed pairs of nuts at time. Other information can be taken from DIN 28120.

ITEM	DESCRIPTION	MATERIAL	QTY
1	Welding Flange	1.4301/1.4404	1
2	Cover Flange	1.4301 / 1.4404	1
3	Gasket	PTFE	2
4	Sight Glass Disc	Tempered	1
5	Nut	T304	8
6	Screw	T304	8

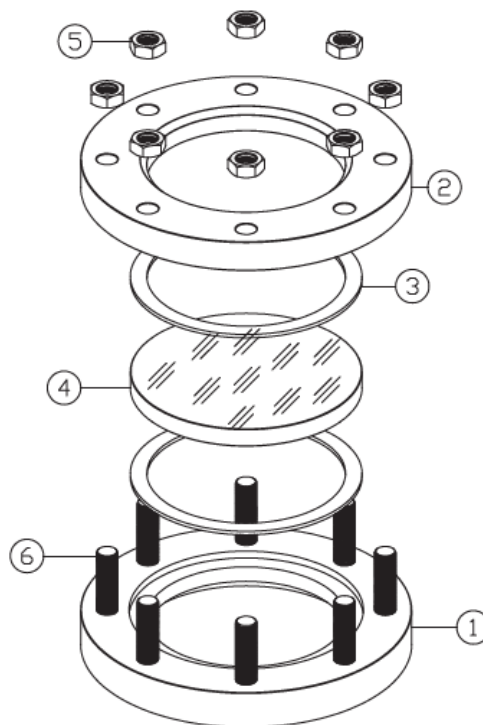

Standard Size * at temperature 50°C / 122°F

CODE	D1 (MM)	D (MM)	SG (MM)	H1 (MM)	H2 (MM)	K (MM)	P.R (BAR)
SGT50DNB/DIN28/89	80	165	100	16	30	125	10/16
SGT80DNB/DIN28/89	100	200	125	20	30	160	10/16
SGT100DNB/DIN28/89	125	220	150	22	30	180	10/16
SGT125DNB/DIN28/89	150	250	175	25	30	210	10/16
SGT150DNB/DIN28/89	175	285	200	30	36	240	10
SGT200DNB/DIN28/89	225	340	250	35	36	295	10

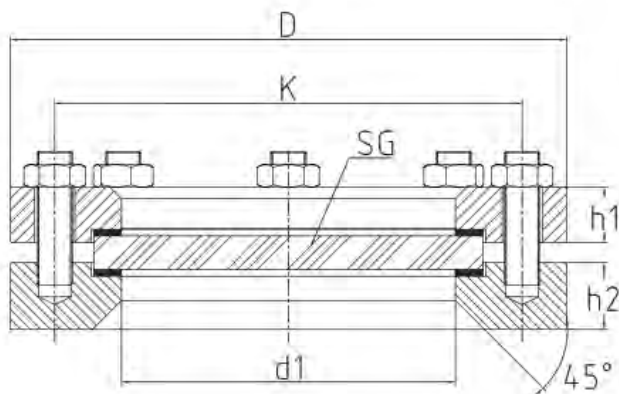

If you want to check for more details please check the following drawing
 *1 Bar = 14.5 Psi = 0.1MPA

Versaline PVC hose



Colour: Transparent

Features:

Flexible hose made with a revolutionary biological PVC, coming almost totally from natural renewable sources. With Steel spiral. Inside and outside completely smooth. Food grade according to the European 2002/72/CE and its amendments, classes A, B, C. Furthermore, the hose is complaint with FDA regulations. Completely free of phthalates and other synthetic plasticizers.

The material allows to save CO2 emissions. Resistant to atmospheric agents and to the lot of chemical substances.

Application:

To deliver liquids and substances in the food industry (expect fatty food)
Like drinks, juices, wine, vinegar and spirits with max. alcohol content of 15% according to European Directives (CE)N. 2023/2006, regarding manufacturing good practice of materials and goods intended to come into contact with foodstuffs.

Ordering information

The hose is available to purchase in 10 mtr unbroken coils. However, you can buy up to a 30mtr unbroken coil in increments of 10 mtr.

Hose is available Ex Stock.

Operating temperature range is +10°C to +60°C

We also supply a variety of hose hygienic fittings.

***SS braided hose and food hoses are also available. ***

PART NO	ID NOMINAL (MM)	OD (MM)	MAX WP (Bar)	BURST PRESSURE (Bar)
HOPVC125	12	18	7	35
HOPVC19	20	27	6	30
HOPVC25	25	33	6	30
HOPVC32	32	40	6	25
HOPVC38	38	47	5	25
HOPVC50	50	60	4	20



Adjustable Feet

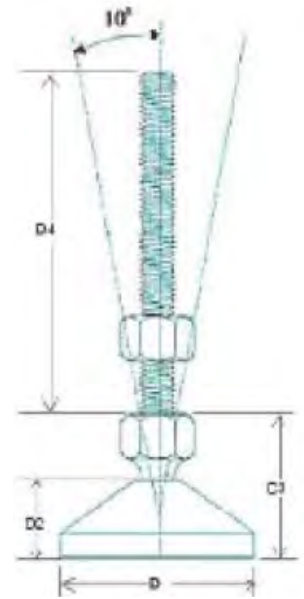

CODE	BASE TYPE	LOAD RATING (KG)	D	D1	D2	D3	D4
TFM8 / 25 / 38SC	CONICAL	300	38	8	14	31	25
TFM8 / 55 / 38SC	CONICAL	300	38	8	14	31	55
TFM10 / 35 / 38SC	CONICAL	300	38	10	14	31	35
TFM10 / 55 / 38SC	CONICAL	300	38	10	14	31	55
TFM10 / 75 / 38SC	CONICAL	300	38	10	14	31	75
TFM10 / 100 / 38SC	CONICAL	300	38	10	14	31	100
TFM12 / 100 / 51SC	CONICAL	500	51	12	15	38	100
TFM12 / 150 / 51SC	CONICAL	500	51	12	15	38	150
TFM16 / 150 / 76SC	CONICAL	1500	76	16	22	50	150
TFM16 / 200 / 76SC	CONICAL	1500	76	16	22	50	200

Table continued on following page

CODE	BASE TYPE	LOAD RATING (KG)	D	D1	D2	D3	D4
TFM20 / 150 / 76SC	CONICAL	2000	76	20	22	55	150
TFM20 / 200 / 76SC	CONICAL	2000	76	20	22	55	200
TFM24 / 150 / 76SC	CONICAL	2000	76	24	22	54	150
TFM24 / 200 / 76SC	CONICAL	2000	76	24	22	54	200
TFM16 / 150 / 102SB	B/DOWN	1500	102	16	22	51	150
TFM16 / 200 / 102SB	B/DOWN	1500	102	16	22	51	200
TFM20 / 150 / 102SB	B/DOWN	2000	102	20	22	55	150
TFM20 / 200 / 102SB	B/DOWN	2000	102	20	22	55	200
TFM24 / 150 / 102SB	B/DOWN	2000	102	24	22	54	150
TFM24 / 200 / 10SB	B/DOWN	2000	102	24	22	54	200

Adjustable Feet - EHEDH & 3A

Type XH

The XH machine foot is certified according to 3A sanitary standard for machine feet: “88-00” and EHEDG Type EL – 1st Class. The patented XH foot is sealing all moving parts 100% hygienically, even if the load on the foot is removed. The XH model is therefore approved for machinery and equipment for the food, dairy, brewing and pharmaceutical industries. It is recommended to use the XH system in environment with the highest hygiene and cleaning requirements.

The XH design reduces time on cleaning to an absolute minimum. The sleeve covers the threaded surface and also functions as a nut. The machine foot admits slopes up to 10° on floors and equipment.

Foot plate					
	H 60	H 80	H 100	H120	H140
Diameter Ø	60 mm	80 mm	100 mm	120 mm	140 mm
Height B	25 mm	26 mm	30 mm	35mm	37 mm
Nom Load	7.000 N	15.000 N	20.000 N	30.000 N	40.000 N

Thread				
Item Number	Thread D	Length A	Length L	
3A 16181	M16	166 mm	78 mm	13 mm
3A 16231	M16	216 mm	110 mm	13 mm
3A 20181	M20	166 mm	78 mm	15 mm
3A 20231	M20	216 mm	110 mm	15 mm
3A 24181	M24	166 mm	78 mm	19 mm
3A 24231	M24	216 mm	110 mm	19 mm
3A 30181	M30	166 mm	78 mm	24 mm
3A 30231	M30	216 mm	110 mm	24 mm
3A 36181	M36	166 mm	78 mm	30 mm
3A 36231	M36	216 mm	110 mm	30 mm

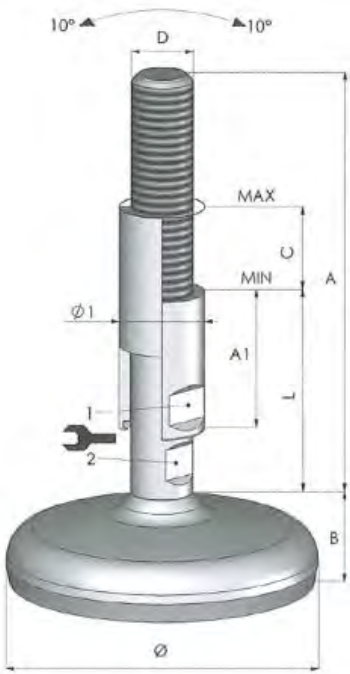

Sleeve					
Item Number	Thread D	Diameter Ø1	Length A1	Length C	
RHO 1655	M16	24.5 mm	55 mm	40 mm	19 mm
RHO 1685	M16	24.5 mm	216 mm	70 mm	19 mm
RHO 2055	M20	29.9 mm	166 mm	40 mm	24 mm
RHO 2085	M20	29.9 mm	216 mm	70 mm	24 mm
RHO 2455	M24	33.0 mm	166 mm	40 mm	27 mm
ROH 2485	M24	33.0 mm	216 mm	70 mm	27 mm
ROH 3055	M30	39.5 mm	166 mm	36 mm	36 mm
ROH 3085	M30	39.5 mm	216 mm	66 mm	36 mm
ROH 3655	M36	49.5 mm	166 mm	36 mm	46 mm
ROH 3685	M36	49.5 mm	216 mm	66 mm	46 mm

Ordering example:

H80 - 3A16181 - RHO1655

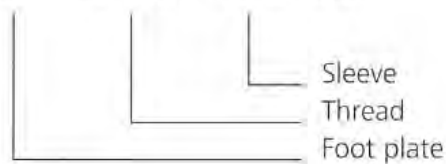

Centrifugal pumps

Suitable for Dairy, Beer, Beverage, Pharmaceutical and Chemical applications.

- 0.5kw to 30kw
 - Flowrate up to 5m³/hr to 270m³/hr
 - Head upto 115cm
 - Available with trolley
- 
- All pumps upto 7.5kw can be supplied with integral frequency inverters , motor to IE3
 - Easy maintenance

Positive displacement pumps

Dosing and Metering

- Dosing pumps for additives, colours, and flavours.
- Supply back pressure valves, injectors, suction tubes and calibration tubes.
- HpE can size your dosing pump, product transfer pump and a static mixer as a complete system.

Piston Pumps

- Powerful line of piston pumps moves extremely difficult materials.
- Pressure ratios up to 12:1 and are ideal for low to medium viscosity materials.
- Flowrates to 53L/min
- Pressures to 80 Bar

Drum unloader pump systems

- Can be used within a combination with either the diaphragm or piston pump.
- Can evacuate medium to high viscosity products from their original 55-gallon (208L) containers in less than 5 minutes
- No dilution or shearing the material.
- Fast evacuation
- Both AODD + piston pump systems available
- Superior plate design with inflatable wiper seals
- Will unload viscosities up to 250,000cps (including caramel)

Rotary Lobe Pumps

Lobe pumps are used in breweries (yeast), the dairy industry (cream, yogurt, cottage cheese), confectionery (caramel, toffee, fondant cream). In the soft drinks industry for the like syrups and concentrates in the pharmaceutical industry on creams and ointments.

Unibloc Compac

- Compact design
- Horizontal or vertical mounting versatility
- Eliminates pump & motor alignment issues
- Safe design with no accessible moving parts.



Lobe Pumps

- Fully machined stainless or coated aluminium bearing housing options
- CIP and SIP capable
- Capacity up to 480 GPM (1.815 LPM)
- Port sizes from 3/8" to 6"
- High temperature compatible up to 200°C



Twinscrew Pumps

- 2 pumps in one
- Slow speeds for product transfer
- Up to 3000rpm for CIP feed and scavenge
- Self-priming and capable of handling up to 60% air / liquid mix
- Can dry run (with flushed mech seals)
- Flow rates up to 180m³/hr – pressures up to 20 Bar

Progressive Cavity

- Fully hygienic PC pump
- Available to up 2.2kw
- Flowrates up to 8.0m³/hr

Peristaltic Pump

- Pressure regulator plus a discharger pulsation damper
- DIN 11856 connections
- Control panel with 5 meters of wire
- Abrasion resistant natural rubber with FDA certification
- Working temperatures (NR) from -20 to 70°C
- Hose maximum admissible pressure: 15 Bar

Liquid Ring

- Designed to handle clean fluids. Fluids without any suspended solid particles
- Self-priming and reversable
- Suitable for wine and oils industry



Homogenisers

The HL homogenisers are 2,3,5 or 6 plunger high pressure homogenisers consisting of a positive displacement, reciprocating high pressure pump, fitted with a homogenising valve assembly, specially selected for each application. The homogenising valve is available in single-or-two stage configuration.

The homogenisers are highly sanitary and fully CIP-able.



Manways

We have a selection round, oval, rectangular manways door and hatches. Along with spray balls, adjustable feet, tank safety equipment, and mixers. For more information on our Manways, Tank Equipment and Mixers visit www.manways.co.uk.

Manway Doors, hatches and seals



Spray balls

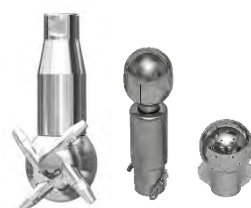

Levelling feet



Tank Safety

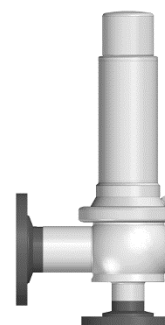
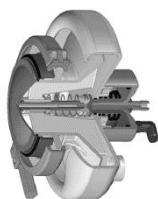

Mixers



Mixers

Vertical agitator – Tandem

The tandem model allows different sealing systems to be installed in accordance with the application.

- Low pressure sealing systems with lip seal or stuffing box
- High pressure or vacuum sealing systems with mechanical seal: single, dry
 - turn or dual cartridge.

Characteristics

Specific sealing system in accordance with application:

Single mechanical seal, dry turn or dual cartridge

Level of finish: individual / foodstuff/ sanitary

Anchor flange: square / DIN 2576 / IEC type

Parallel geared motor

Interchangeability of agitator components

Materials

Parts in contact with the product in stainless steel AISI 316L

Parts not in contact with the product in stainless steel AISI 304L, carbon steel or others

Options

Other materials: AISI 304L, AISI 904L, Hastelloy etc

Thermosiphon pressurised / cooled mechanical seal

Contra rotator reassembly

Other anchor flanges

Guide tripod

Control panel

Frequency or mechanical speed variator

Stainless steel casing



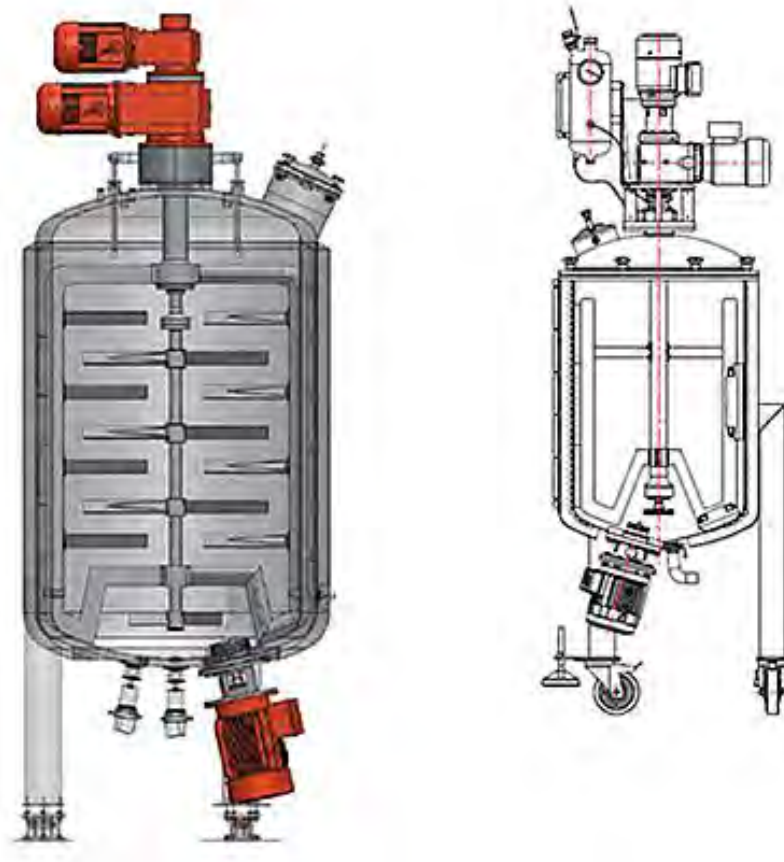

Contractor agitating system comprising tandem agitator with ANCORA vane with scrapers, a vertical VMD agitator with COWLES disc and deep mixer. Thermosiphon cooled mechanical seal, along with the tower and tank anchoring system, ensure the seal tightness of the reactor.

Application used to prepare high viscosity cosmetic products.

Lateral agitators: Food Industry

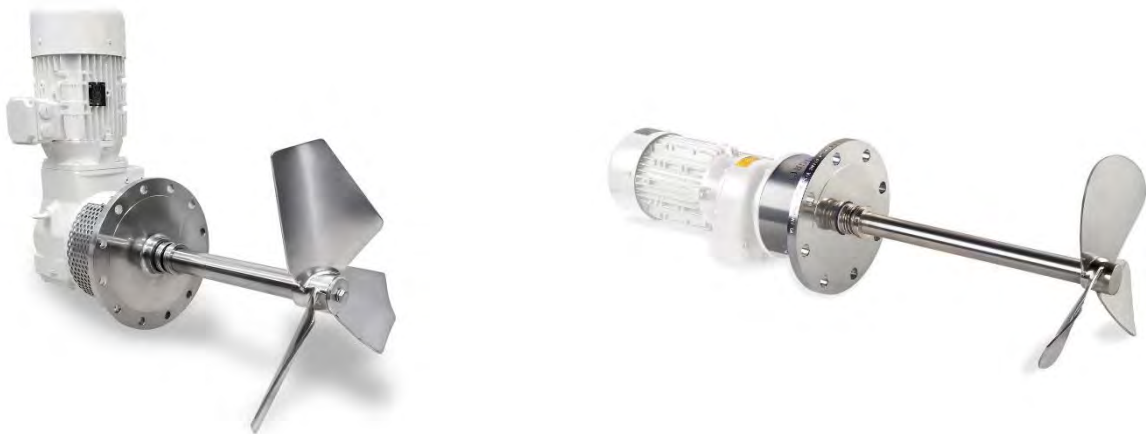

Lateral agitators are highly suitable for maintaining and mixing products stored in medium and large volume tanks. The design allows a high level of homogenisation of the mixture, which is why they are extensively used in the food industry, especially in the dairy sector.

These models are installed in the lowest part of the vessel with different distances to the bottom, and slanted in line with the characteristics of the tank (shape and size). Moreover, these agitators are fitted with two systems of shaft sealing. On the inner part, where the shaft is in contact with the product, there is a mechanical seal whilst the external part is fitted with a stuffing box. All these properties together provide effective sealing and a high degree of hygiene, two conditions which are essential in the food industry.

Working at low turnovers per minute, providing soft treatment of the milk and an optimal circulation ratio for maximum heat exchange. These are the main reasons why these agitators are very useful for cooling and keeping milk at low temperatures inside isothermal vessels.

Apart from milk cooling and maintenance, these units are used for:

- Dissolution of products like sugar syrup, yeast, fats, powdered foods, thickeners etc
- Product homogenisation (wines, liquors, spices and flavourings in brines, vegetable oils, fats etc)
- Heat exchangers
- Dilutions (whey, concentrates)
- Product/suspension maintenance (soft drinks, orange, clementine, lemon juices etc)
- Mixing flavours, additives, preservatives, etc.

Characteristics

- DIN 2576 anchor flange
- Level of finish: food stuff / Sanitary
- Gearbox with high performance helicoidal gears
- Single mechanical seal sealing system
- Gamma / Marine propeller
- Simplicity of parts

Materials

Shaft and propeller manufactured stainless steel AISI 316L
 Mechanical seal C/C/N

Options

- Control panel
- Safety stuffing box
- Mechanical seal S/S/V or dual
- Shaft and propeller covering against corrosion and wearing up
- Motor Cover

Other materials:

Big flow gamma propeller

Other anchor systems:

- Mechanical or frequency converter
- Other shaft lengths

$H=(2/2.5)\times D$

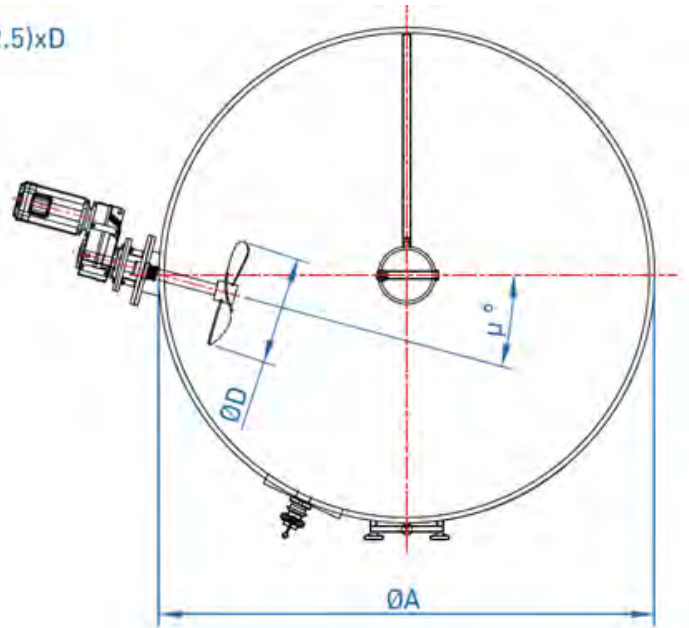
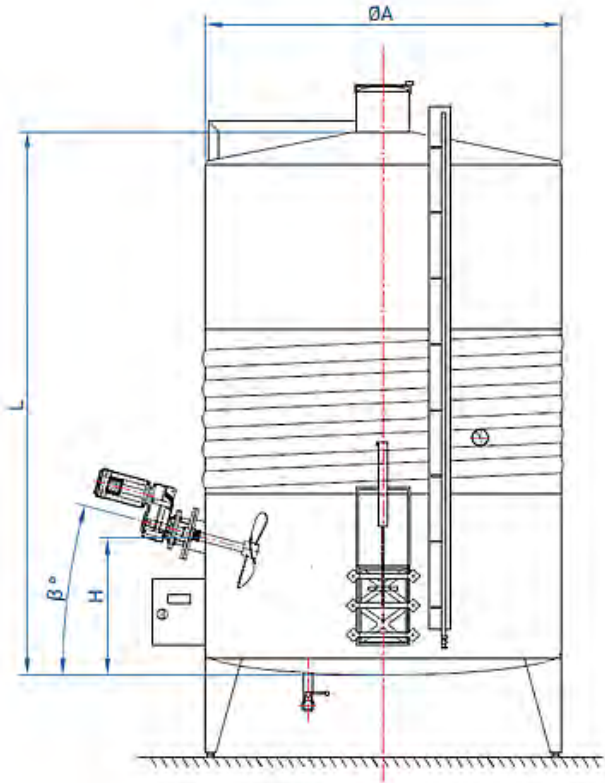

INSTALLATION PARAMETERS							
A/L	2	1	0.5	0.3	0.25	0.2	0.16
β°	5	15	20	35	45	55	65
μ°	15	12	10	8	5	2	0

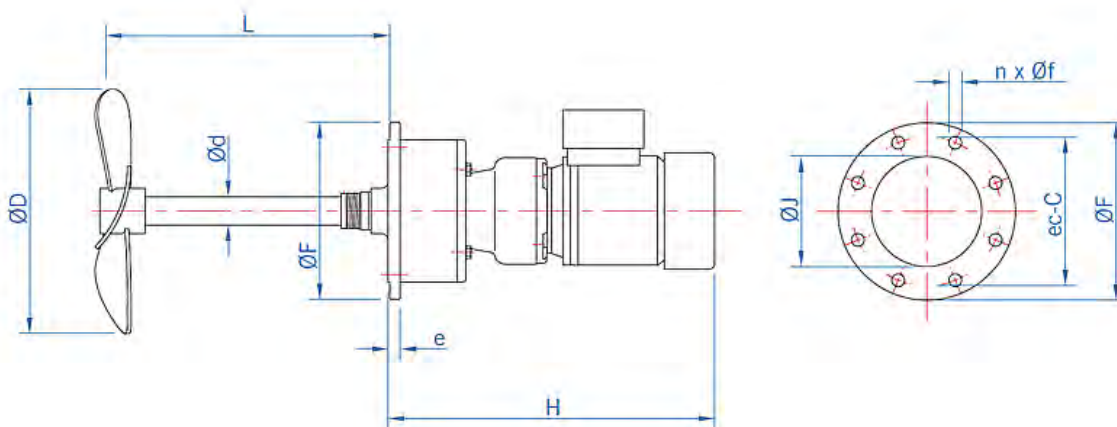
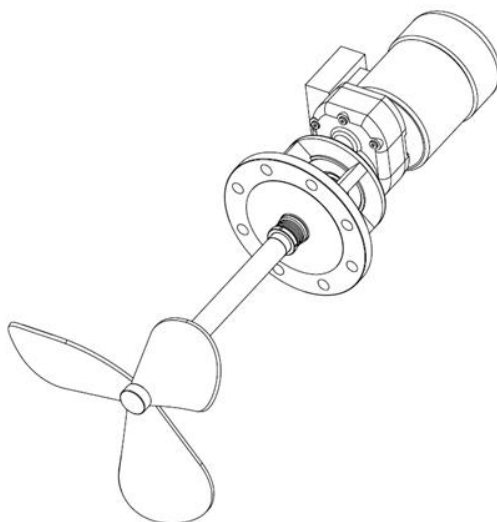

MODEL	OVERALL DIMENSIONS						ANCHOR FLANGE according to DIN 2576 PN10					
	Power (kW)	d	D	e	H	L	DN	C	f	F	J	n
LECOR 0.37-135/300	0.37	40	300	22	463	500	150	240	22	285	169	8
LECOR 0.55-200/300	0.55	40	300	22	463	500	150	240	22	285	169	8
LECOR 0.75-200/400	0.75	40	400	22	480	500	150	240	22	285	169	8
LECOR 1.1-250/400	1.1	40	400	22	525	500	150	240	22	285	169	8
LECOR 1.5-200/500	1.5	40	500	22	525	500	150	240	22	285	169	8
LECOR 2.2-250/500	2.2	40	500	22	555	500	150	240	22	285	169	8
LECOR 3-200/600	3	50	600	24	670	500	200	350	22	340	220	8
LECOR 4-200/650	4	60	650	26	725	600	250	400	22	395	274	12

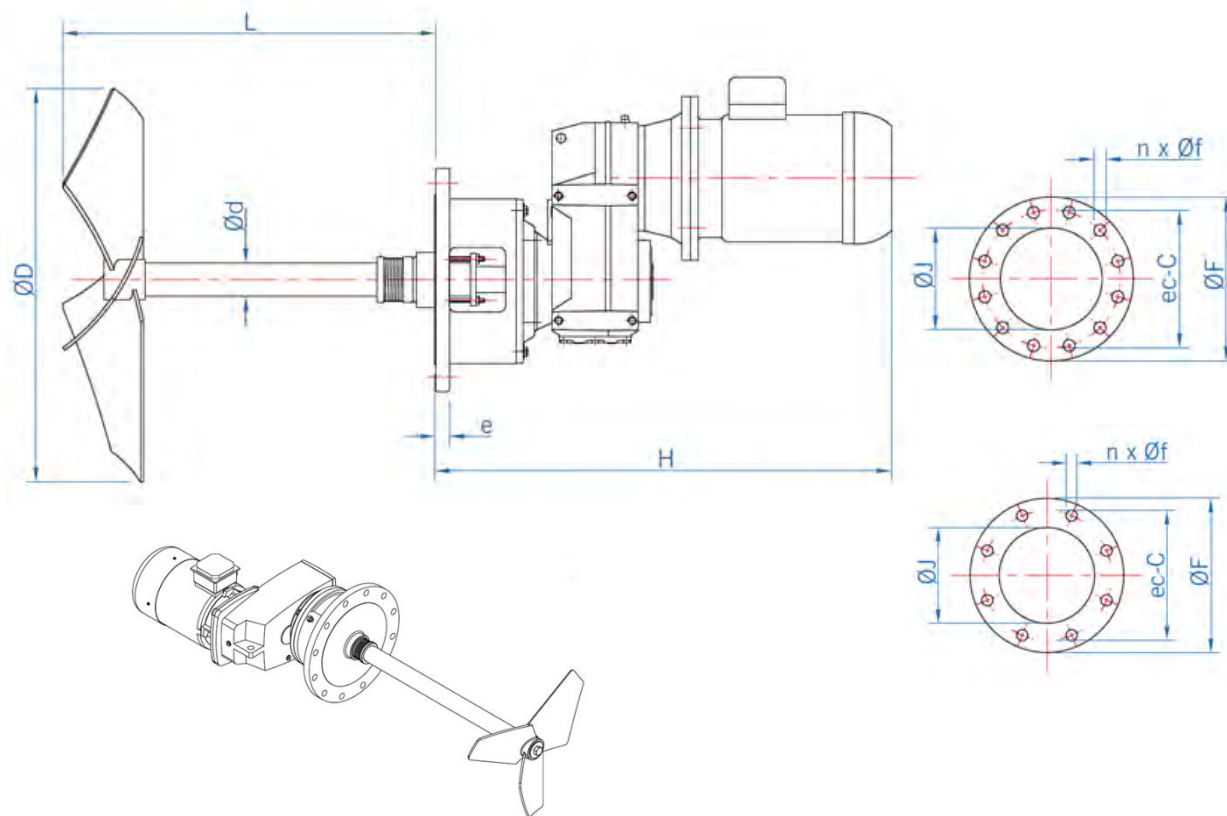

OVERALL DIMENSIONS								ANCHOR FLANGE according to DIN 2576 PN10				
MODEL	POWER (KW)	d	D	e	H	L	DN	C	f	F	J	n
LMRE 037-300/250	0.37	35	250	22	472	400	125	210	18	250	140.5	8
LMRE 0.55-300/275	0.55	35	275	22	494	400	125	210	18	250	140.5	8
LMRE 0.75-300/300	0.75	40	300	22	524	500	150	240	22	285	169	8
LMRE 1.1-300/325	1.1	40	325	22	665	500	150	240	22	285	169	8
LMRE 1.5-300/350	1.5	40	350	22	675	500	150	240	22	285	169	8
LMRE 2.2-300/400	2.2	40	400	24	627	500	200	295	22	340	220	8
LMRE 3-300/450	3	50	450	24	757	500	200	295	22	340	220	8
LMRE 4-300/500	4	50	500	24	805	500	200	295	22	340	220	8
LMRE 5.5-300/500	5.5	50	500	24	876	500	200	295	22	340	220	8
LMRE 7.5-300/600	7.5	50	600	24	885	600	200	295	22	340	220	8
LMRE 9.2-300/600	9.2	60	600	26	904	600	250	350	22	395	274	12
LMRE 11-300/650	11	60	650	26	1010	600	250	350	22	395	274	12
LMRE 15-300/700	15	70	700	26	1075	700	300	400	22	445	325	12
LMRE 18.5-300/700	18.5	70	700	26	1200	700	300	400	22	445	325	12
LMRE 22-300/800	22	70	800	26	1235	700	300	400	22	445	325	12

IBC vertical agitator

IBC vertical agitators are widely used in the pharmaceutical industry because of their high performance and efficient agitation plus their low cost. The high versatility of these agitators comes from the different sizes, the range of impeller types and the coaxial geared-motor, which has a wide range of selectable speeds.

Applications

The IBC design changes in line with agitation characteristics and application requirements, with one or more impellers of the same or different kinds being used to provide the agitation required for each system. The level of finish and the design of the agitator ensure safety conditions and high degrees of hygiene. All these characteristics make the IBC highly recommended for the following operations:

- Dilutions, dissolutions and homogenisations
- Product maintenance
- Suspensions
- Chemical product homogenisation
- Temperature homogenisation

Characteristics

Level of finish: Sanitary

IEC Anchor flange

Coaxial gears gearbox

Interchangeable agitation components

Easy assembly / dismantling

Materials

Parts in contact with the product is SS AISI 316L

Parts without contact in SS AISI 304L, carbon steel and others

Options

Other materials: SS AISI 304L, SS AISI 904L, Hastelloy, etc

Reinforcement turrets

Other anchoring flanges

Pneumatic motor

Control panel

Frequency converter

Gearbox covering



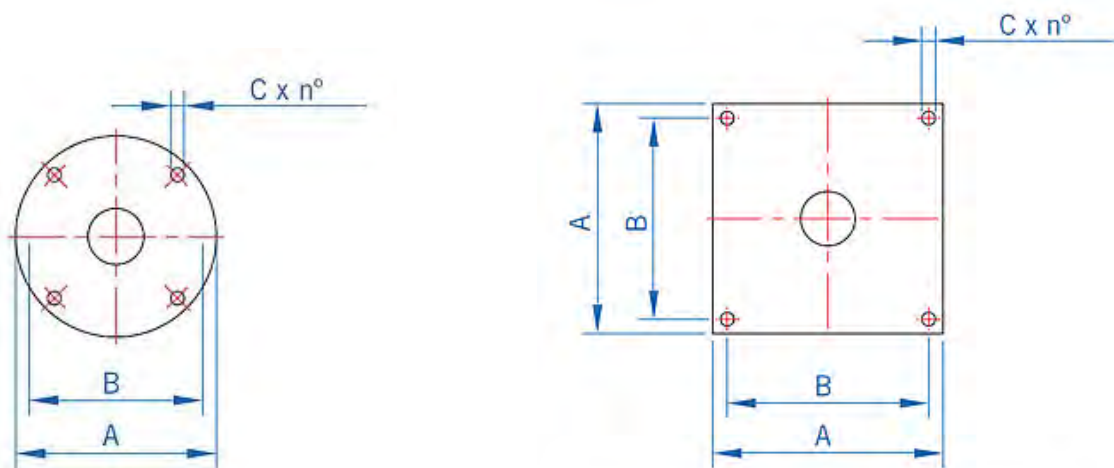
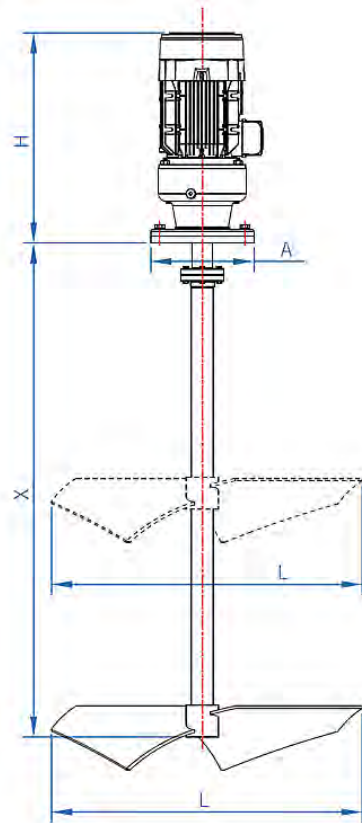

OVERALL DIMENSIONS IBC				
FLANGE	A	B	C	n°
IEC 160	160	130	9	4x90°
IEC 200	200	165	12	4x90°
IEC 250	250	215	14	4x90°

OVERALL DIMENSIONS IBC				
FLANGE	A	B	C	n°
250 x 250	250	200	18	4
300 x 300	300	250	18	4
400 x 400	400	350	18	4

Tank Vents

Vent/20/56

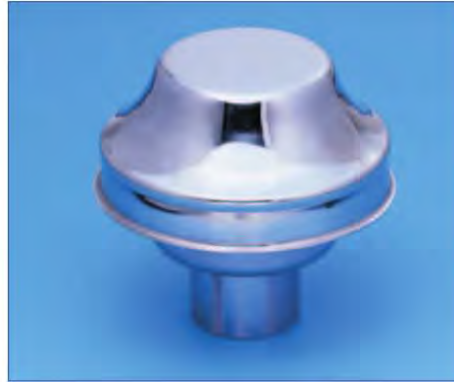
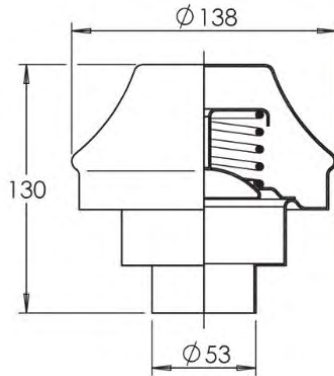

Mounted vertically on the top of a tank, this vent or pressure equalising valve is used to vent air to or from the tank when filling or emptying. Under no flow conditions the valve is closed isolating the tank contents from atmosphere.

Material: 316L Stainless Steel

Opening positive pressure: +0.006 Bar

Opening Negative Pressure: -0.13 Bar

Max Vent Rate: -100m³/hr

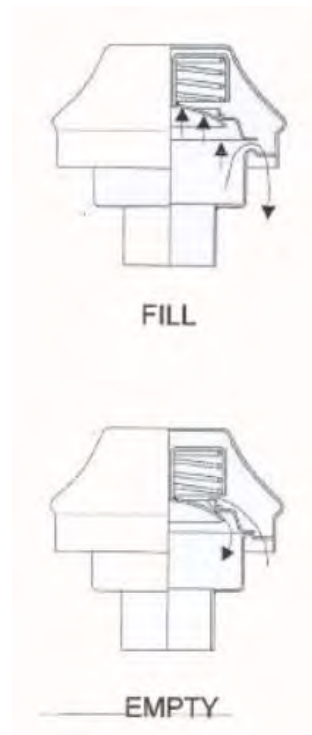

Vent /A50B



Relief valve in Stainless Steel, two way (pressure and vacuum), with oil bath working, maximum flow 1000hL/h.

In stainless steel AISI 304 or AISI 316L

Weight: 2.5kg

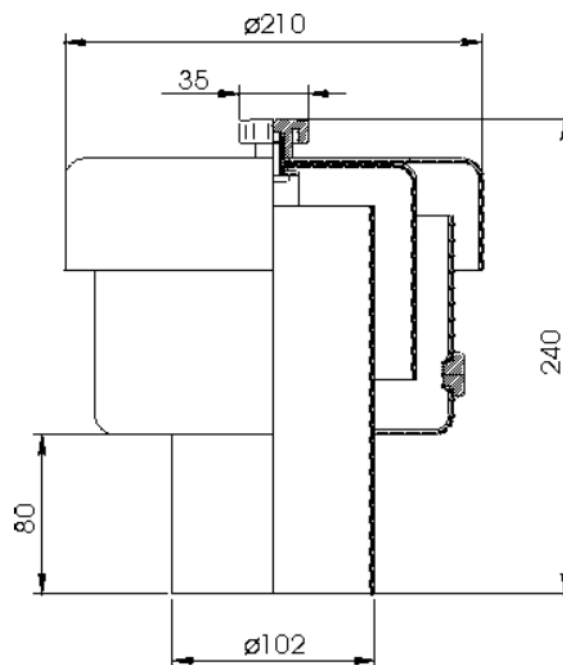

Evoguard Pumps



Design features

Operating data

- Flow rate up to 100 m³/h
- Delivery head up to 80 m
- Operating pressure max. PN 16
- Temperature 95 °C (higher on request)

Motor IE3, type B35, according to IEC

EPDM sealings according to FDA alternative materials such as HNBR, FKM on request

Installation dimensions in metric measurements DN 50 – DN 125 (DIN 11851, DIN 32676 usw.)

Designed according to the legal requirements of the EU machine directive 2006/42/EC

Component inspection by the Technical Control Board TÜV Süd (pressure test, safety test, strength test, ...)

Characteristic curves Evoguard pumps H1CP

2.900 rpm., water 20 °C, max. impellers

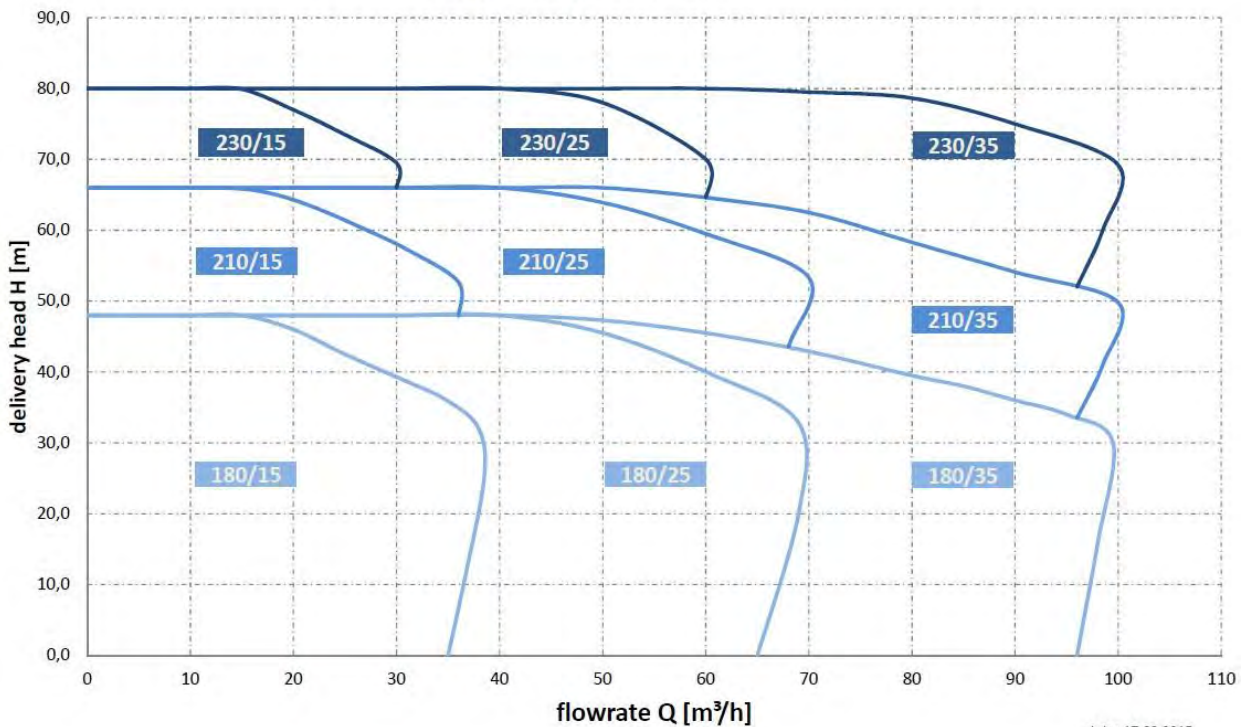

state: 17.02.2015

Design

Block on motor feet

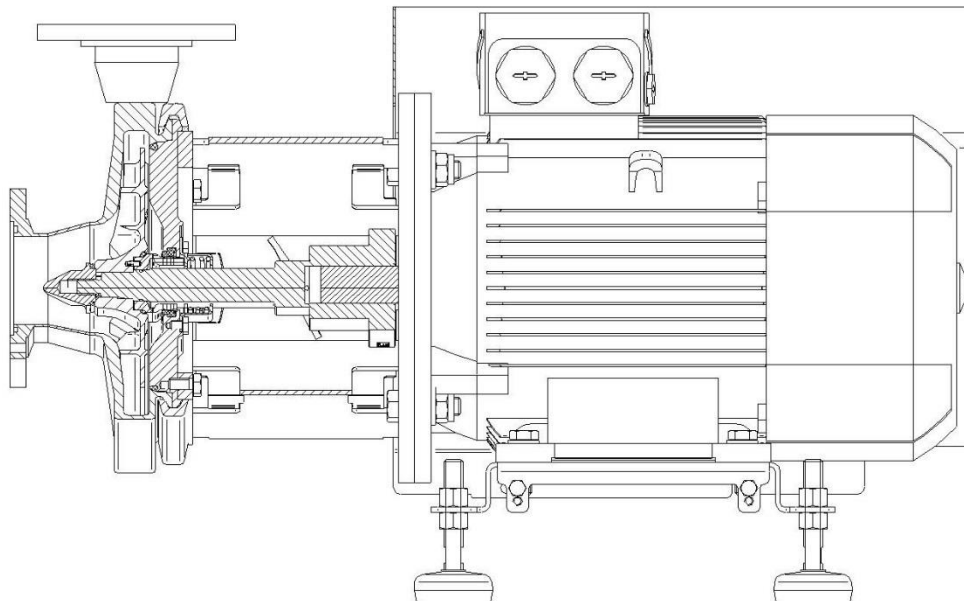

Motor hood and pivot supports
can be retrofitted

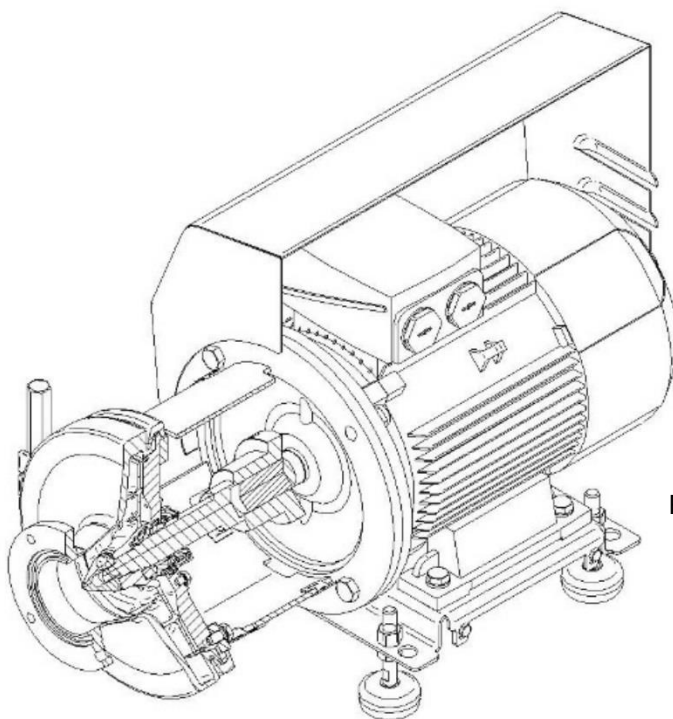

Rotatable housing

Product room

Designed according to the EHEDG guidelines DOC17 and DOC 25.



Abbildung 5 Gleitringdichtung im Produktstrom



Abbildung 9 Hygienegerecht konstruierter Lippendichtring

- Smooth surfaces in the product room; solid material
- Sealing without dead space or recess
- Counter ring with “open” nut for optimal cleaning
- Sliding surface near to the impeller
- Spring and attachment out of product room

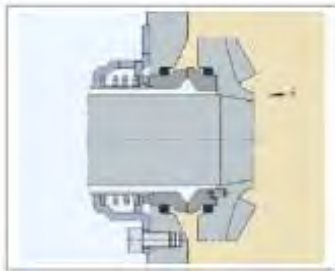
SMS SIZES	DN 25	DN 38
SURFACE	Surface finish in contact with product: Outside finish:	$Ra \leq 0.8\mu$ $Ra \leq 1.6\mu$

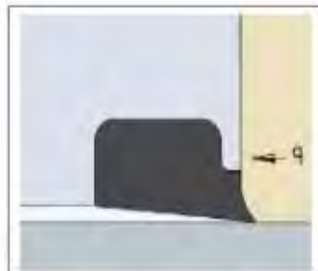
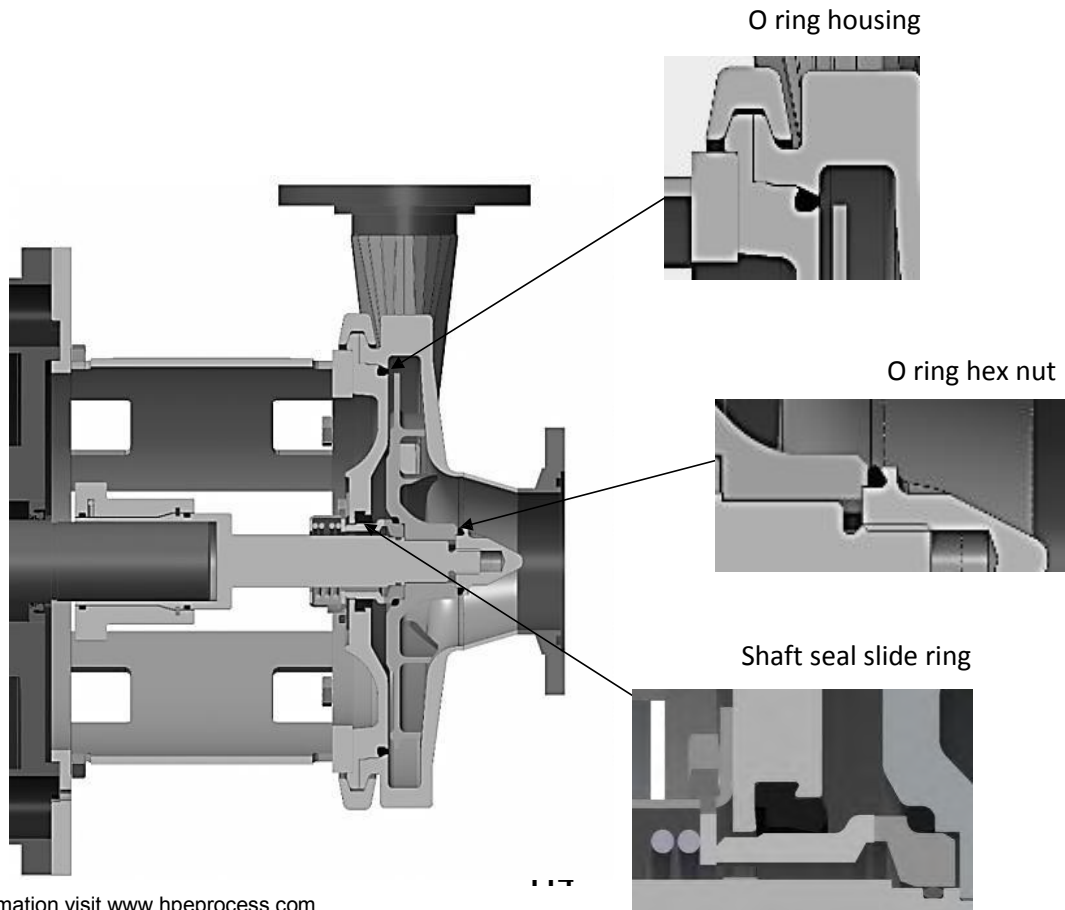

For more information visit www.hpeprocess.com

Technical characteristics

Motor shaft connected to the impeller by a hydraulic locking mechanism

- self-centering
- clearance can easily be set
- simple installation

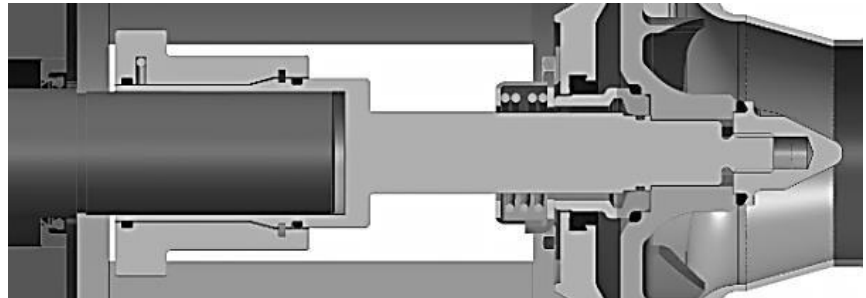

Impeller with swept-back blades and relief holes

- Optimised flushing
- Optimised cleaning
- Reduced axial forces
- High efficiency

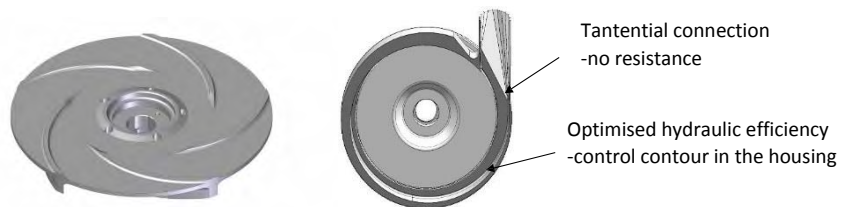

Energy savings resulting from optimization:

- of the housing and of the impeller
Least possible production stops
- less time and personnel requirements for service and cleaning
Low stocking of replacement parts due to modular design

Calculation of life cycle costs

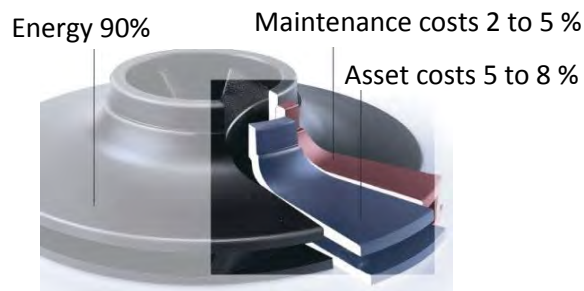

Technical main characteristics of the axial face seal

- Modular design – dismountable in separate parts
- Sliding ring and counter ring are dismountable without separating the pump from the motor
- Spring is outside of the product room
- Large gap between shaft and sliding ring to indicate defect
- No wear of the pump shaft- sliding ring is stationary in the cover

Additional characteristics

- Use of same parts
- Shaft seal of the sliding ring can be cleaned from the back
- Pressure reversal-proof up to 2.5 bar of differential pressure
- Change from single-acting version due to double-acting version possible

Axial face seal
Single-acting version for hydraulic lines
Material: carbon / silicon carbide (standard)



Double acting version optionally available: Eg for aseptic lines with the use of flushing or a buffer medium.

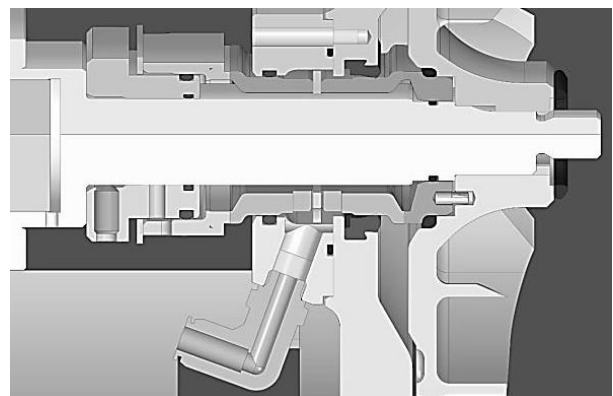

Field testing starting 08.2013

46 Pumps operated in field tests: start in August 2013



Leisslingen / Mixer
Deaerator, booster pump
Circulation, filler, syrup
Since 08.2013



Weihenstephan
Hot wort 1 since 11.2013
Cold wort 2, CIP pump trub since 11.2014



Brewery Kuchlbauer
Beer 3 pieces, CIP pump since 04.2014



Brewery Jacob
Filtration, mash, wort, beer since
04.2014

Employment of the pumps

Water preparation



Brewery



Mineral spring



Pump configuration

Detailsicht		Einstellungen	Förderhöhe H	Leistung P	Wirkungsgrad ETA	NPSH
Pumpenbezeichnung						
Pumpe:	210/25	Auswahl				
Pumpennummer	5	DatenblattFreitext				
Pumpentyp	H1CP					
Gehäusegröße	210	Saug- / Druckstutzen				
Laufradhöhe [mm]	25	Saugstutzen	DN 80			
Pumpenart	Einstufig	Druckstutzen	DN 65			
Einsatzgebiet	Hygienisch					
Antrieb						
<input checked="" type="checkbox"/> FU	Frequenz [Hz]	50	Nennspannung [V]	400	Nenndrehzahl	2940
	Polzahl	2	Netzspannung [V]	400	Nennleist. [kW]	15
Betriebspunkt						
Fördermenge Q [m³/h]	50					
Förderhöhe H [m]	55	Rücksetzen				
Laufreddurchmesser [mm]	200					
Drehzahl	2928,3	=	48,81	[Hz]	Umrechnen	
Förderhöhe H [m]	55,01					
Leistung P [kW]	11,32	<	14,94	[kW]		
Wirkungsgrad [%]	66,06	Best-Punkt				
Spezifische Drehzahl	16,28					
Medium						
Medium	Wasser	Dichte [kg/m³]	998,210			
Temperatur [°]	20	Viskosität [mPas]	1,002			

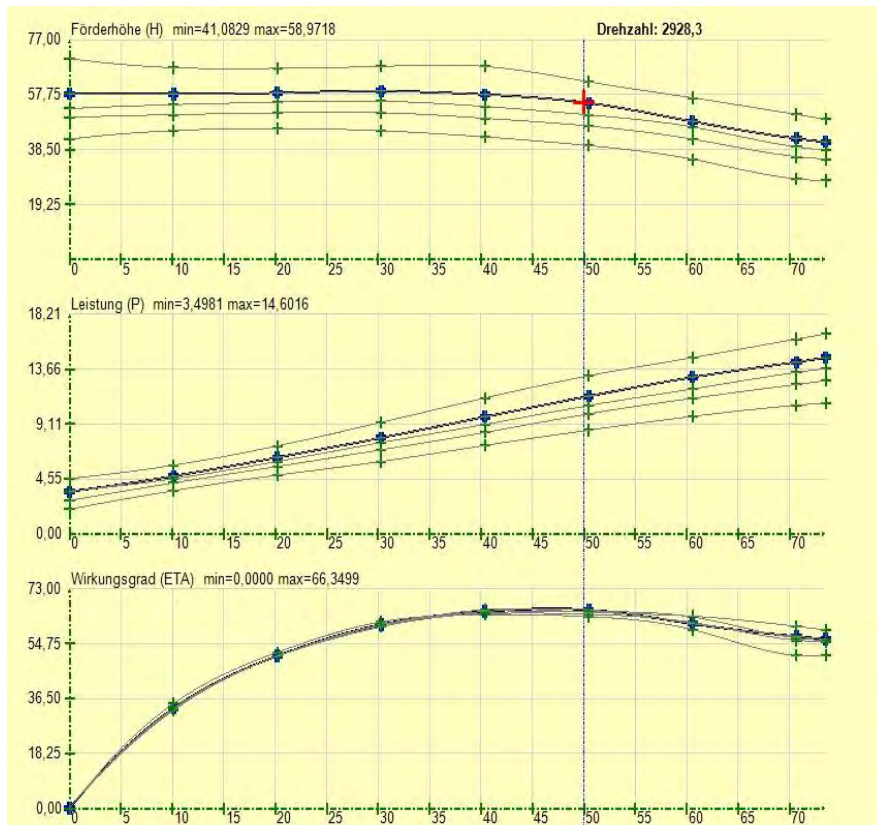

Pumpendatenblatt - 210/25

Produktdaten

Pumpe	210/25	Pumpenart	Einstufig
Pumpentyp	H1CP	Lafraddurchmesser [mm]	200
Gehäusegröße	210	Medium	Wasser
Lafradhöhe [mm]	25	Temperatur [°]	20
Einsatzgebiet	Hygienisch		

Betriebspunkt

Fördermenge Q [m³/h]	50	verb. Motorleistung P [kW]	15
Förderhöhe H [m]	55	Leistung P [kW]	11,32
		Wirkungsgrad [%]	66,06

Pumpenkennlinien

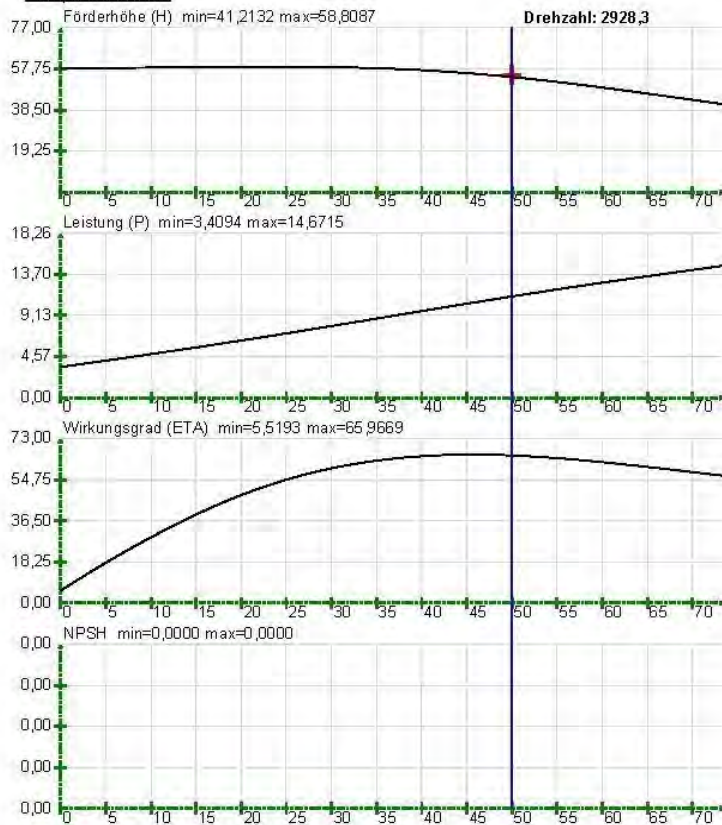

Delivery times & pump tests

Delivery time after order is 4 to 6 weeks

Messung der Pumpe:

0903867881 0100	Pumpe H1CP 210/25 D200 FN100080 SQB 15
-----------------	--

getestet am: 22.06.2015
von: Obendorfer T.

Motor	BG160
Nennleistung KW	15/18
Nennzahl rpm.	2940/3540
Nennstrom AD	26,5
Nennstrom AY	15,2
Spannung VD	400/480
Spannung VY	690/830
Frequenz Hz	50/60

Spalt Laufrad-Gehäusedeckel [mm]	0,8
Nennweite Saug/Druckseite	100/80
Typ Anschluss	Flansch mit Nut
Laufraddurchmesser [mm]	200
Laufradhöhe [mm]	25

Pumpentest mit	400	V
	50	Hz

Pump Test

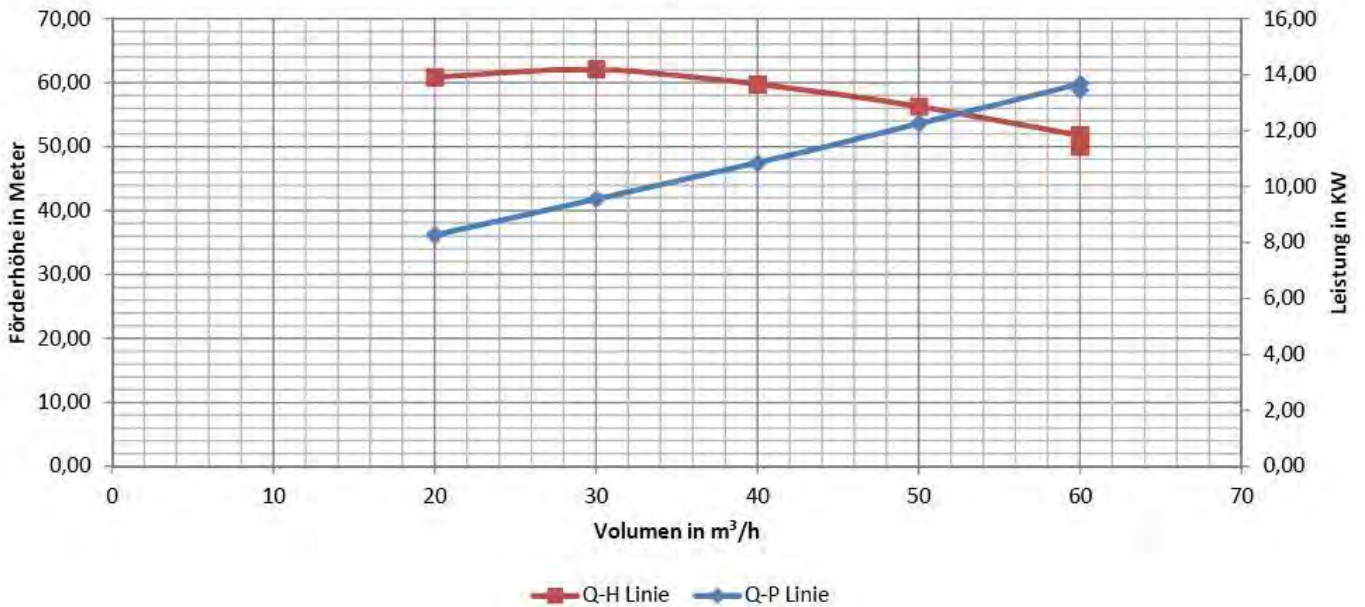

Performance sheet

Every pump is tested internally according to DIN EN ISO 9906 prior to delivery

The performance data – flow rate, delivery head, motor performance – are included with every pump delivery.

Your benefits

- Parts clearly identified
 - High process reliability
 - Maintenance-friendly
 - New connections to motors
 - New safe seal concept
 - Reduced energy consumption
 - Certified product quality
 - Robust materials
 - Innovation based on experience
 - Everything from one source
-
- Designed according to the legal requirements of the EU machine directive 2006 / 42 / EC
 - Component inspection by the technical control board (pressure test, safety test, strength testing.....)



Evoguard Butterfly Valves

Used as a cost-effective shut-off device for product and CIP.



Control Butterfly Valve

Combination



Special parts



Stepless handle

Extension piece

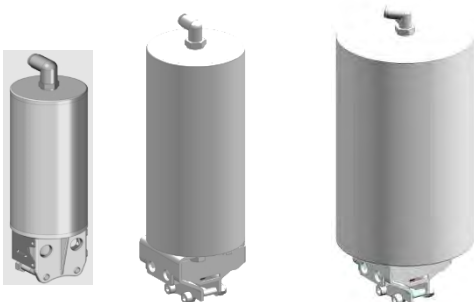

Actuator diameter	mm	D53	D89	D129
Volume of air	dm ³	0,10	0,36	0,88
Torque NC	Nm	16	38	100
Air pressure min. NC	bar / psi	4,5 / 65	4,5 / 65	4,5 / 65
Air pressure min. NO	bar / psi	5,5 / 80	5,5 / 80	5,5 / 80
Installation Butterfly Valve:		DN 25 - 50	DN 65 - 100	DN 125 - 150

Butterfly technical details

- Volume of the seal as small as possible equipped with expansion grooves
- Bevelled seat design and dividing lines outside of the product room
- Seal material EPDM compliant with FDA 21 CFR 177.2600 – Optional HNBR, FKM, VMQ
- Bushings against fretting
- Disc solid design

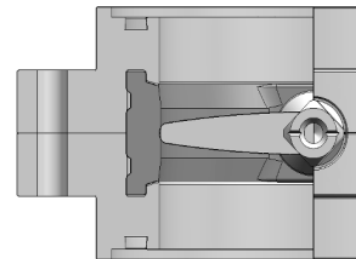
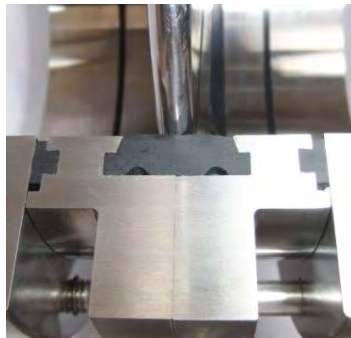

Customer benefits

- Actuator – welded version: maintenance -free, designed to 1,000,00 cycles
- State of the art seal material
- Improvement of seals lifetime by optimising
- Easy assembly
- No special parts required to mount proximity switches to pneumatic actuators
- EHEDG Certification



Evoguard Range Seat Valve

Used or shut -off in pipe system

High valve requirements: Product pressure up to 330 psi (22.7 bar)

Prevention of pressure blows

Special requirements to sealing systems

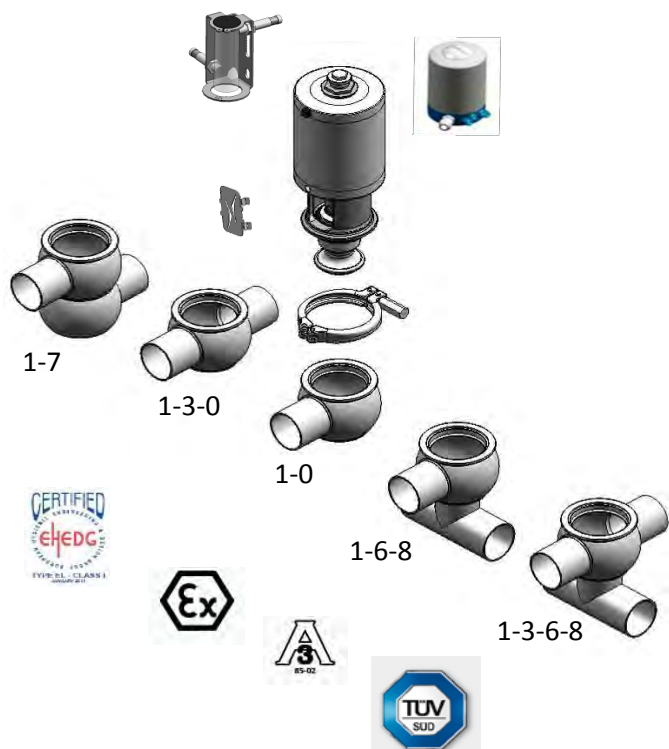

Special part

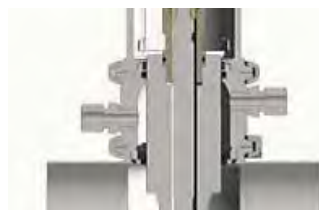

Sterile Lock

Variants



Tank Outlet Valve



Overflow Valve



Divert Valve

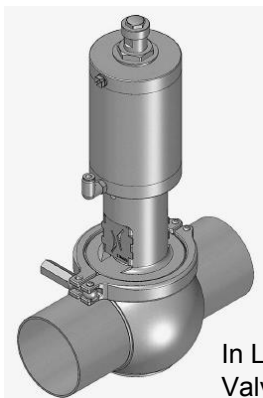

In Line Shield Valve

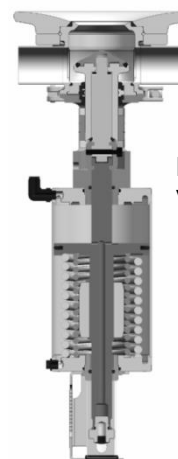

Long Stroke Valve

Seat Valve

Technical details

- Actuator allocation according to product pressure: 87psi (6bar); 145psi (10bar); 330psi(22.7 bar)
- Valve disc with balancer
- Housing PN 25 (360psi) free from dead space
- Seal material EPDM compliant with FDA 21 CFR 177.2600 –
 - Optional HNBR, FKM, VMQ
- Shaft seal
 - Resistance to rip-out
 - With stripping function
- Metallic Stop
- Two-part valve disc – screwed with lock against rotation
- Defined space requirements for the seal

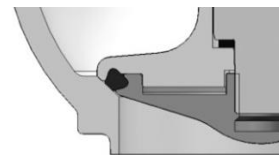
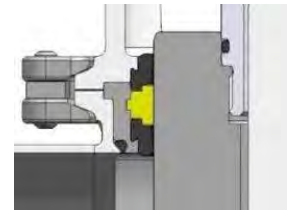
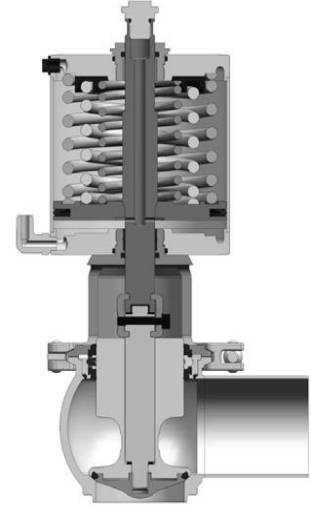

Customer benefits

- Actuator – welded version: maintenance -free, designed to 1,000,000 cycles
- State-of-the-art seal material
- Resistance to rip-out and fluid behind the seal
- Improvement of seals lifetime by optimising
- Easy assembly
- Safety PN 25 (360psi) – Pressure test according to Pressure Equipment Directive
- EHEDG certification

Evoguard Range Double Seal Valve

Used for mixproof separation of incompatible media



Variants

Design for vertical valve blocks



Double seal valve

Technical details

- Actuator allocation according to product pressure: 87psi (6bar); 145psi (10 bar); 330psi (22.7bar)
- Valve disc with balancer
- Two seals are used between the pipes for shutting off
- The valves isolation chamber is equipped with two rinsing valves
- Sealing direct to the product room
- Three-part valve disc – screwed with lock against isolation

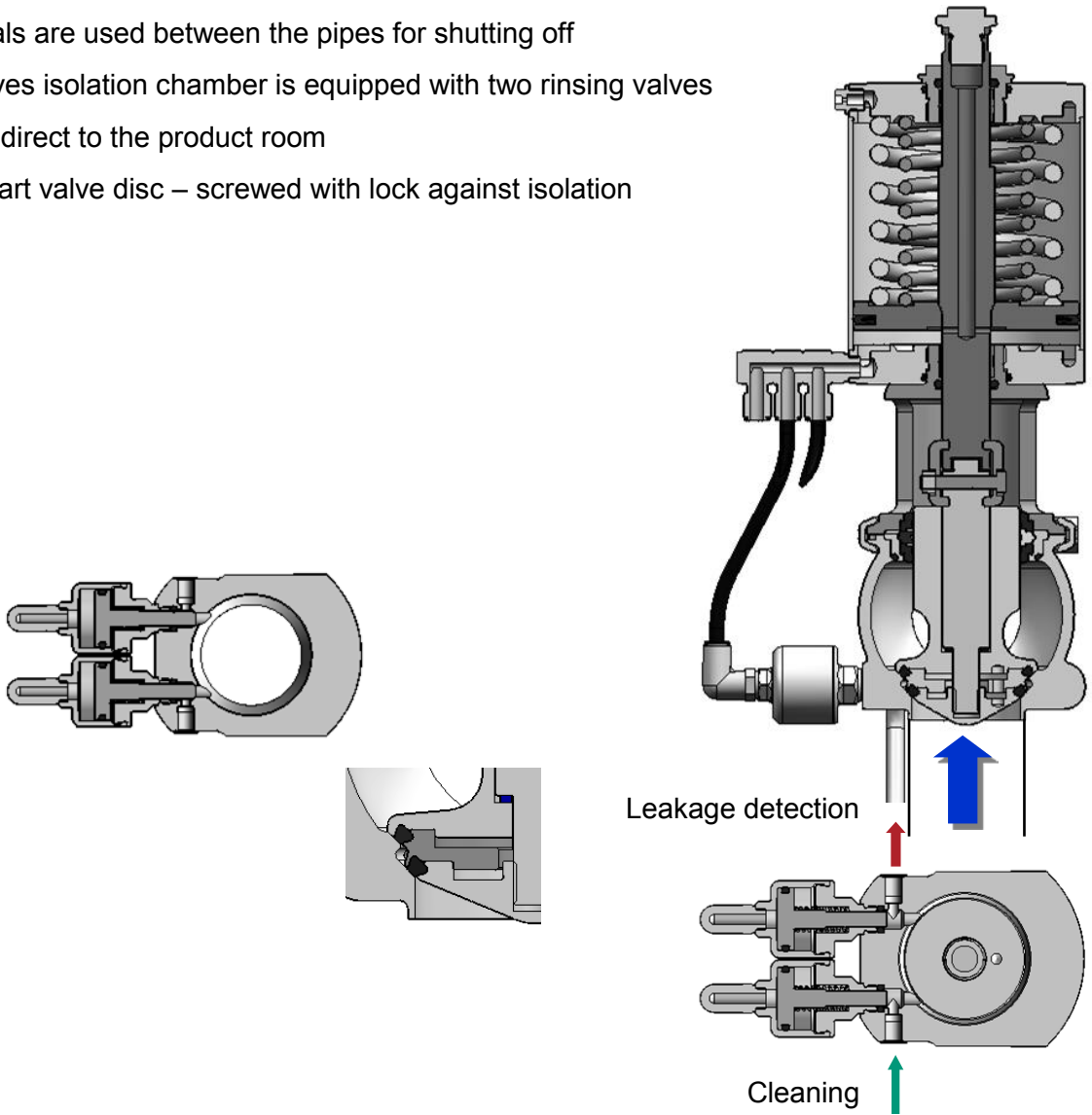

Customer benefits

- Design and sealing systems analogues to seat valve
- Economical alternative to mixproof valve
- Alternative to leakage butterfly valve



Evoguard Range Mixproof Valve

Used for mixproof separation of incompatible media

- Pressure resistance
- Change-over without leakage
- Cleaning the leakage chamber

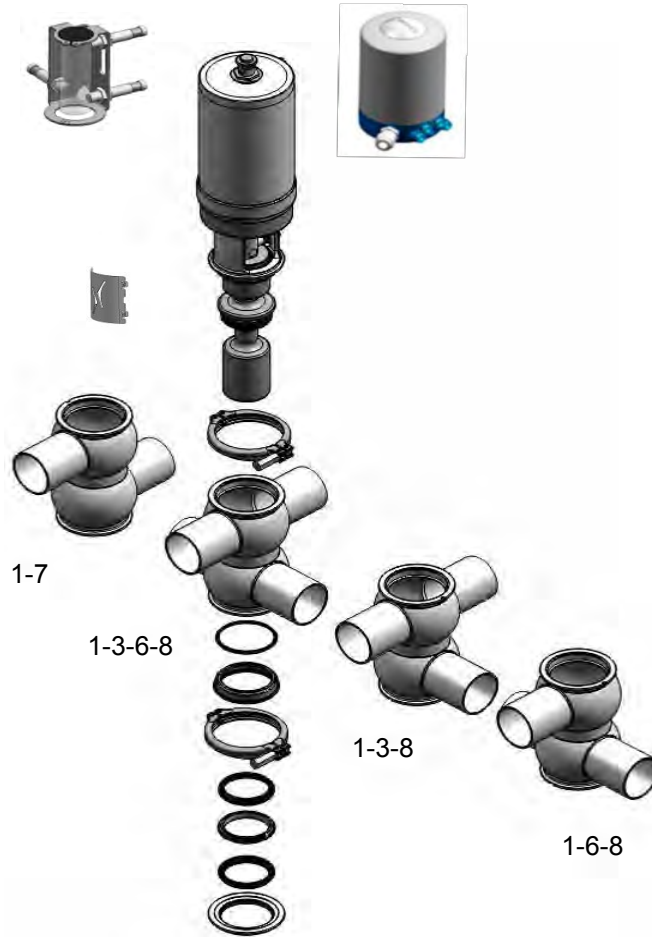

Special Parts

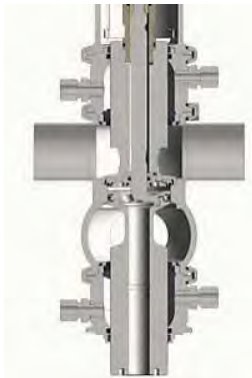

Sterile Lock



Double seat tank outlet valve



Double seat divert valve



Mixproof valve piggable

Variants Mixproof Valve

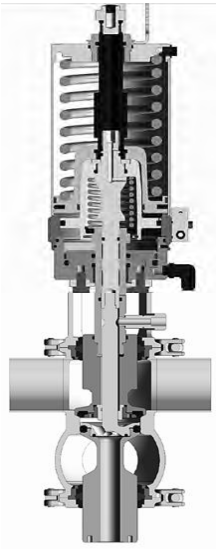

ML

Upper and lower valve disc liftable

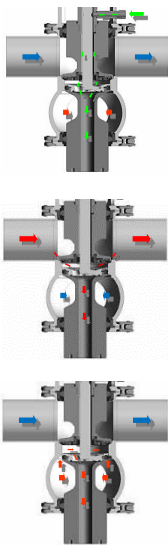
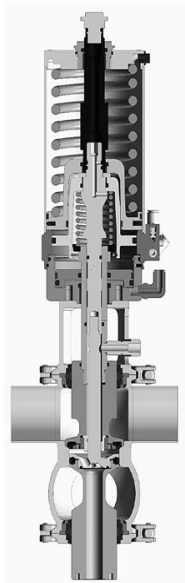
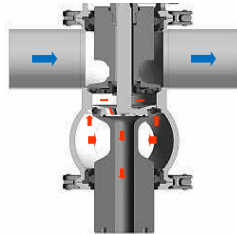

MR

Upper and lower valve disc liftable

Additionally flushing

MF

Flushing

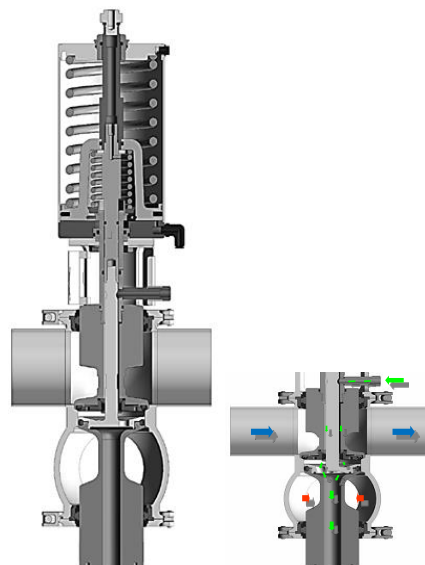

Mixproof Valve

- Actuator with integrated lifting features
- Valve discs with balancer
- Seal material EPDM complaint with FDA 21 CFR 177.2600 – optional HNBR, FKM
- Shaft seal
 - Resistance to rip-out
 - With stripping function
- Housing 25 (360psi) – free from dead space
- Two-part valve disc, screwed
- Identical seals
- Sealing directly in front of the product room no gap between
- Only two seals required

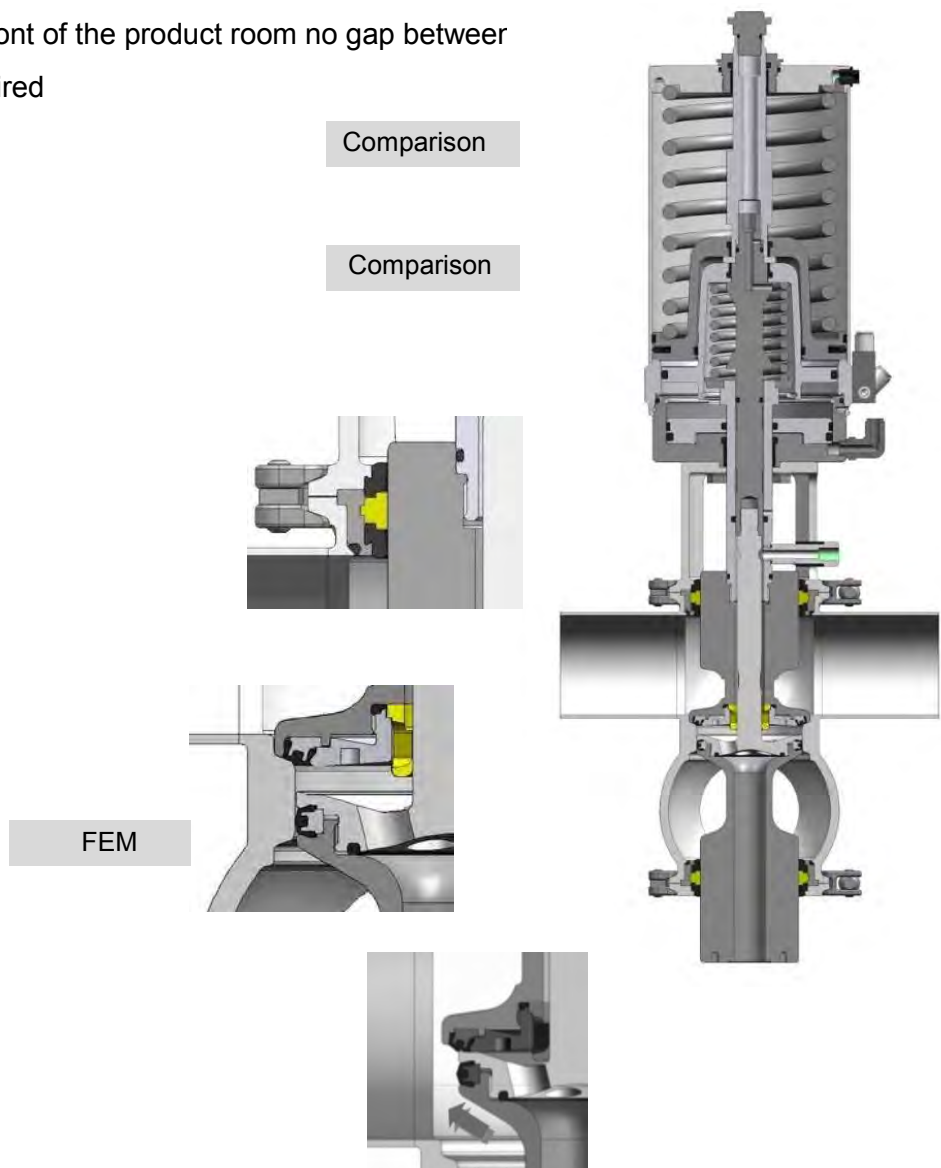

Customer benefits

- Actuator: maintenance -free fast lifting time – Less air consumption
- New sealing system:
- State of the art seal material
- Improvement of seals lifetime by optimising
- Resistance to rip out and fluid behind
- Easy assembly - 'mix up' impossible
- Safety and pressure resistance according legal requirements
- EHEDG certification



Evoguard Range Control Valve

Used for fast and exact regulation in processes

Variar

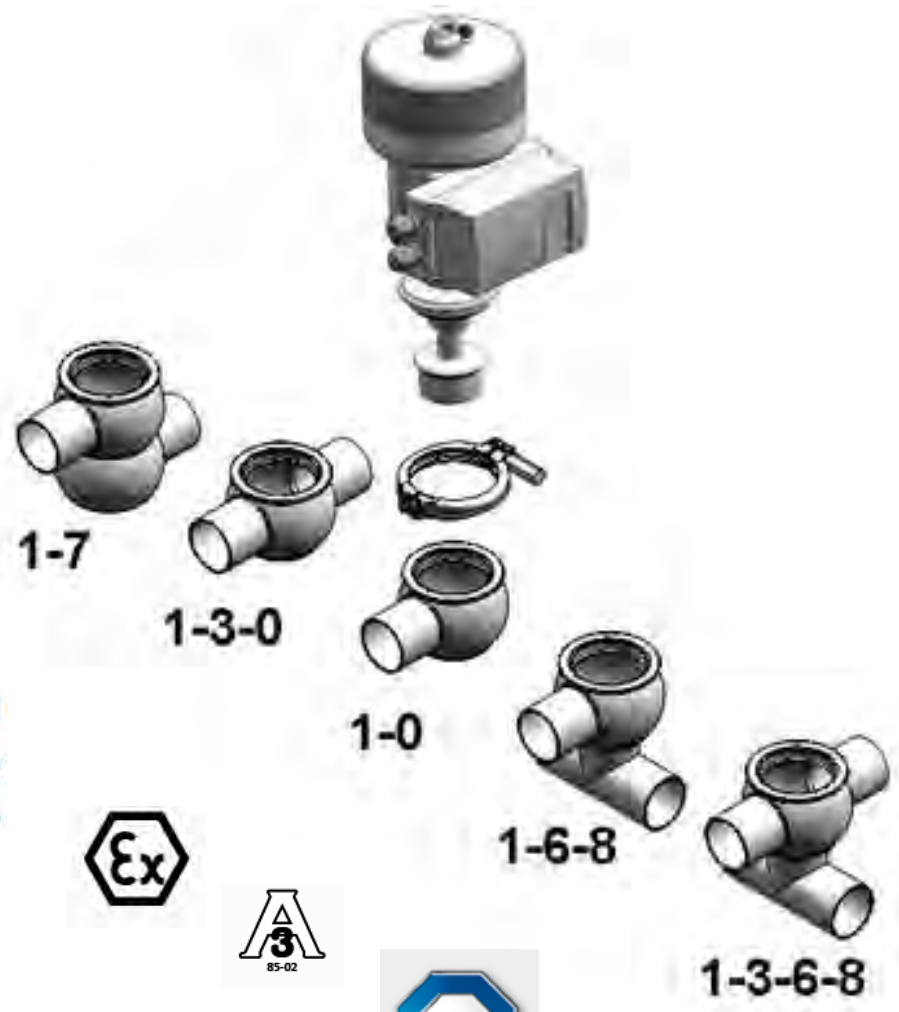

Gas Control Valve

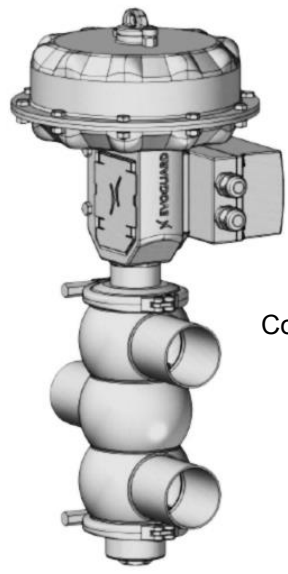

Control Divert Valve

Control Valve

- Diaphragm actuator with mounted position controller
- Control cone equal percentage in standard

Allocation seat – Ø/KV value

Seat-Ø	Value		Stroke 20			Stroke 30		
	Kvs m ³ /h	Cvs US gal/min	DN25	DN40	DN50	DN65	DN80	DN100
3	0,1	0,116	x					
	0,16	0,186						
5	0,25	0,29	x					
	0,4	0,46						
10	0,63	0,73	x	x				
	1	1,16						
	1,6	1,86						
19	2,5	2,9	x	x	x			
	4	4,64						
26	6,3	7,31	x	x	x			
	10	11,6						
38	16	18,56	x	x	x	x	x	x
	25	29						
50	32	37,12	x	x	x	x	x	x
	40	46,4						
66	63	73,1				x	x	x
81	100	116					x	x
100	160	185,6						x

Customer benefits

- Design and sealing systems analogues to seat valve
- Actuator allocation according to product pressure

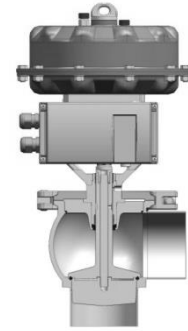

Hygienic

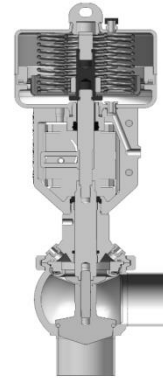

ESL

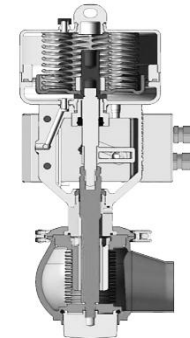

Aseptic

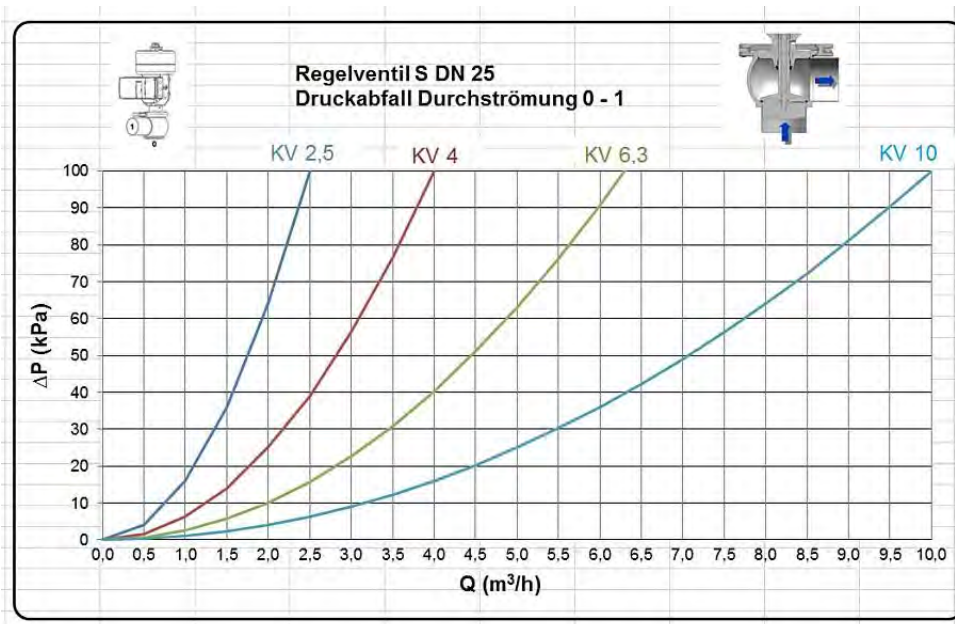

Evoguard Range ESL (Extended Shelf Life) Seat Valve

Used for shut-off in pipe system in ESL processes (like sensitive soft drinks without preservatives and beverages which must not be distributed in a cold chain)

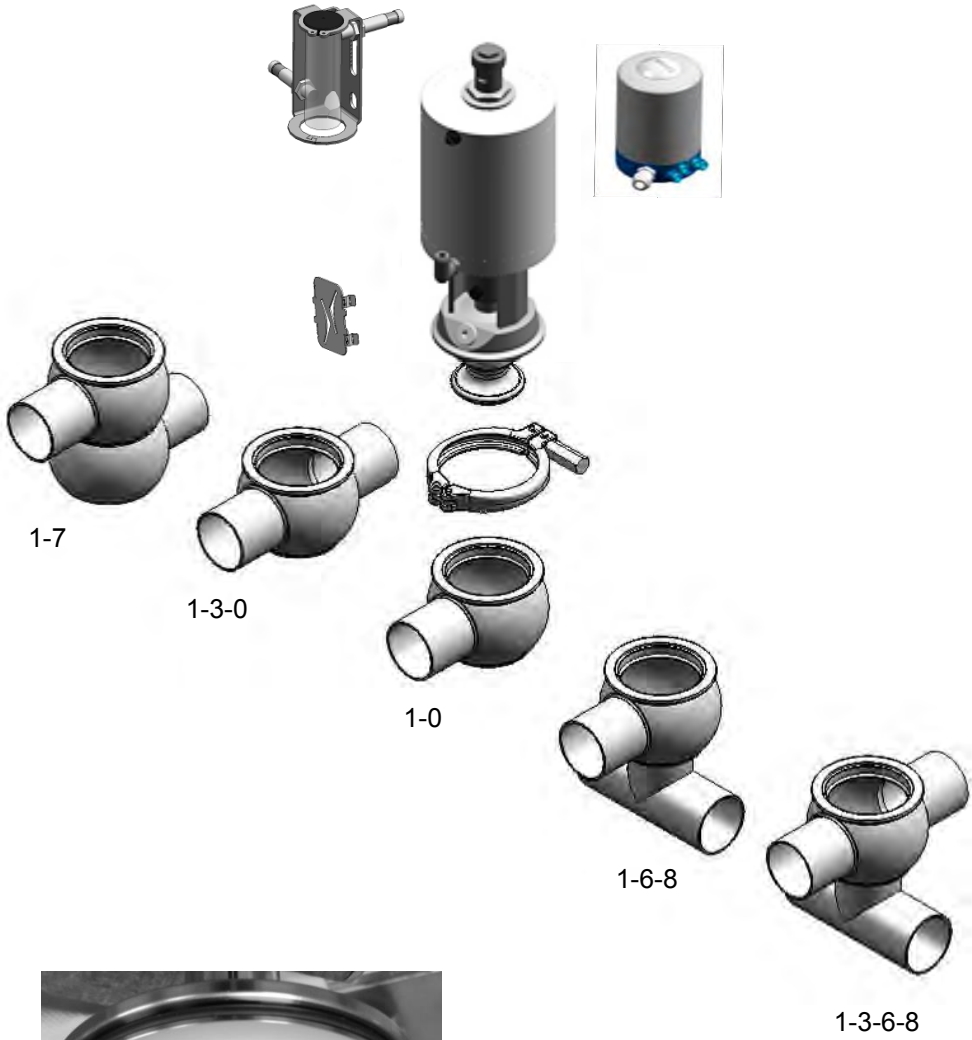

Technical details

- Actuator allocation according to product pressure: 87psi (6 bar); 145psi (10 bar)
- Connections
 - Bellow monitoring
 - Leakage removal
- Housing without dome or sump PN 25 (360psi)
- Shaft seal replaced by membranous sealing element material PTFE compound
- Defined contact pressure at the sealing point
- Seal material PTFE compound
- Final design subject to internal approval



Customer benefits

- Cost attractive version in ESL processes
- Actuator – welded version: maintenance -free, designed to 1,000,000 cycles
- Resistant to all products and cleaning media
- Optimal cleaning conditions
- Designed to 500,000 cycles
- EHEDG certification (under way)

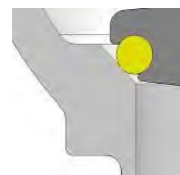
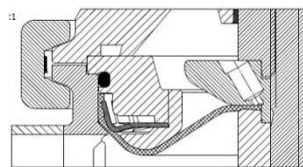
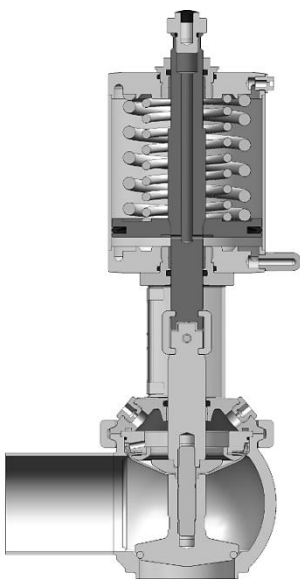

Evoguard Range ESL (Extended Shelf Life) Mixproof Valve

Used for mixproof separation of incompatible media in ESL processes (like sensitive soft drinks without preservatives and beverages which must not be distributed in a cold chain)

- Cleaning the leakage chamber by lifting valve discs or flushing

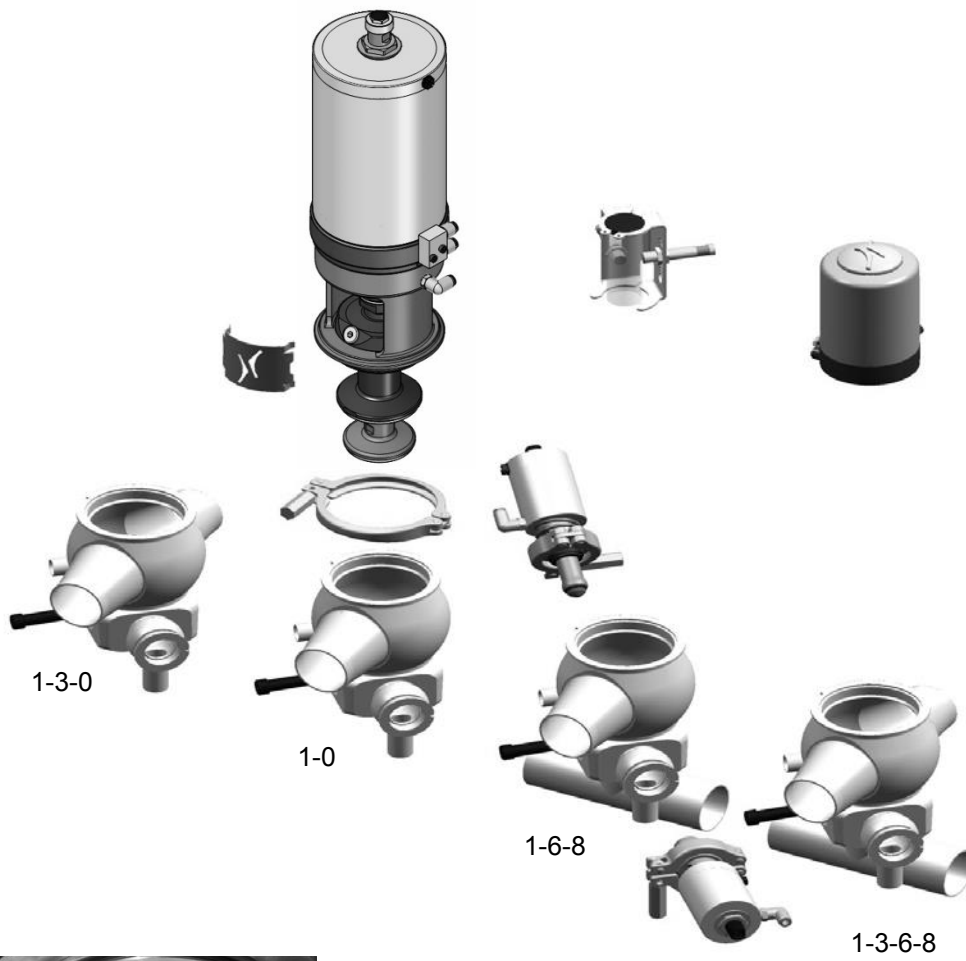

Technical details

- Actuator allocation according product pressure: 87psi (6 bar); 145psi (10 bar)
- Actuator with integrated lifting features
- Connections:
 - Bellow monitoring
 - Leakage removal
- Housing without dome or sump PN25 (360psi)
- Free cross section
- Shaft seal replaced by membranous sealing element material PTFE compound
- Defined contact pressure at the sealing point
- Seal material PTFE compound
- Valve under angle

Customer benefits

- Cost attractive version in ESL processes
- Actuator – welded version: Maintenance-free, designed to 1,000,000 cycles
- Resistant to all products and cleaning media
- Optimal cleaning conditions
- Free cross section
- Designed to 500,000 cycles
- EHEDG certification (underway)

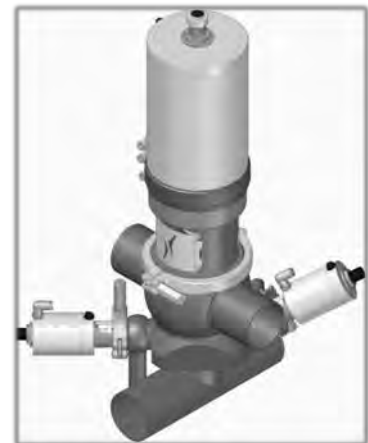
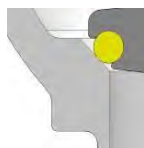
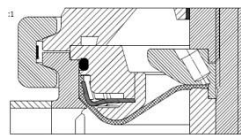

Evoguard Range Aseptic Seat Valve

Used for shut-off in aseptic and sterile processes

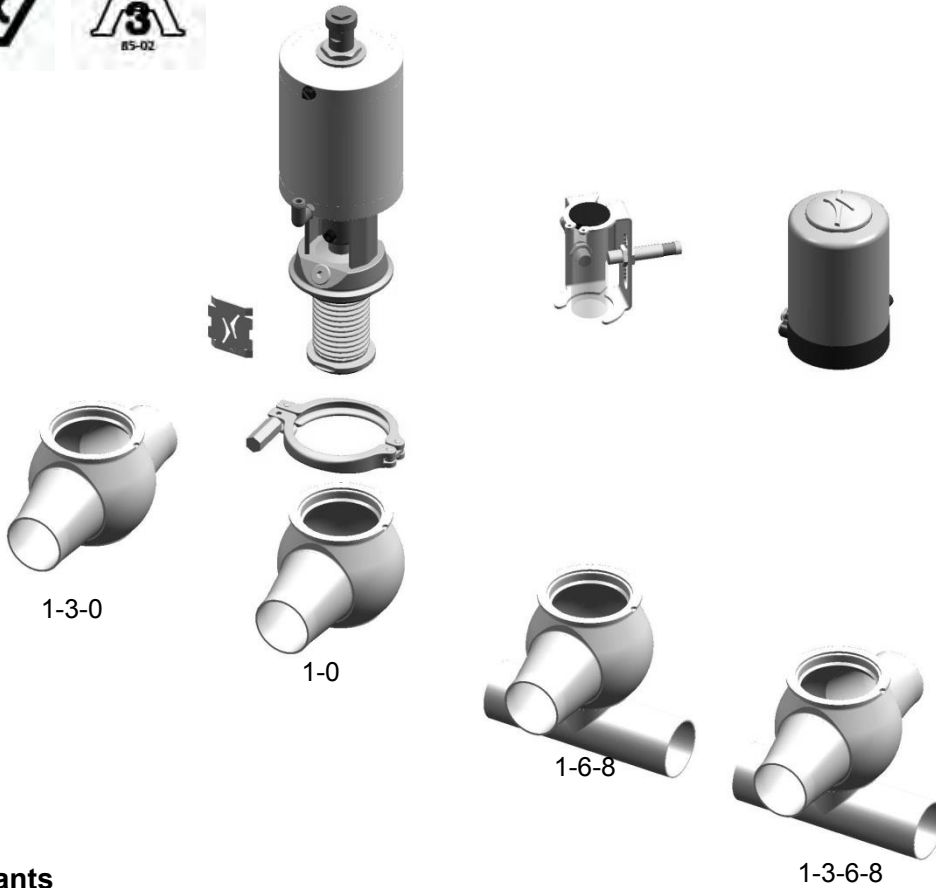

Variants

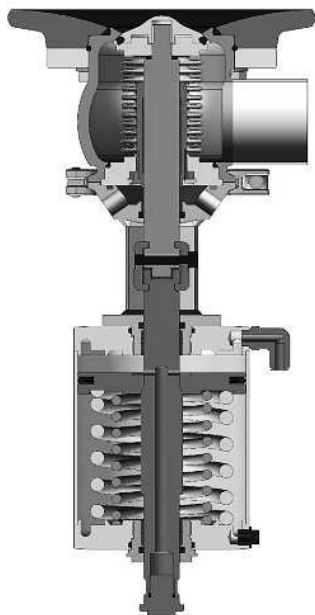

Aseptic tank outlet valve

Technical details

- Actuator allocation to product pressure: 87psi (6 bar); 145psi (10 bar);
- Valve spindle is decoupled
- Connections:
 - Bellow monitoring
 - Leakage removal
- Housing PN 25 (360 psi)
- Support for bellow
- Two-part valve disc – screwed: according to Single Seat Valve
 - Sealing material: EPDM / FKM highly fluorinated
- One-part valve disc:
 - Sealing material PTFE compound



Customer benefits

- Hermetical sealing by means of the metal bellow
- No product contamination from the ambient atmosphere
- Bellow support: blocking at dismounting
 - No overstress for the bellow guidance under vibration
 - Raising running life during operation
- Design and sealing systems analogues to seat valve
- Actuator allocation according to product pressure

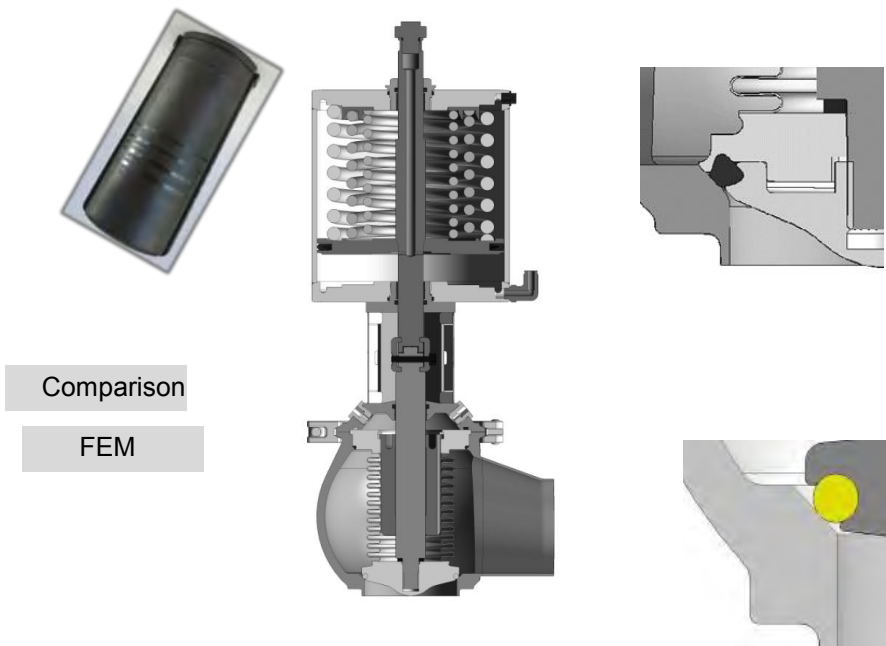

Evoguard Range Aseptic Double Seat Valve

Used for safe media separation in aseptic and sterile process applications

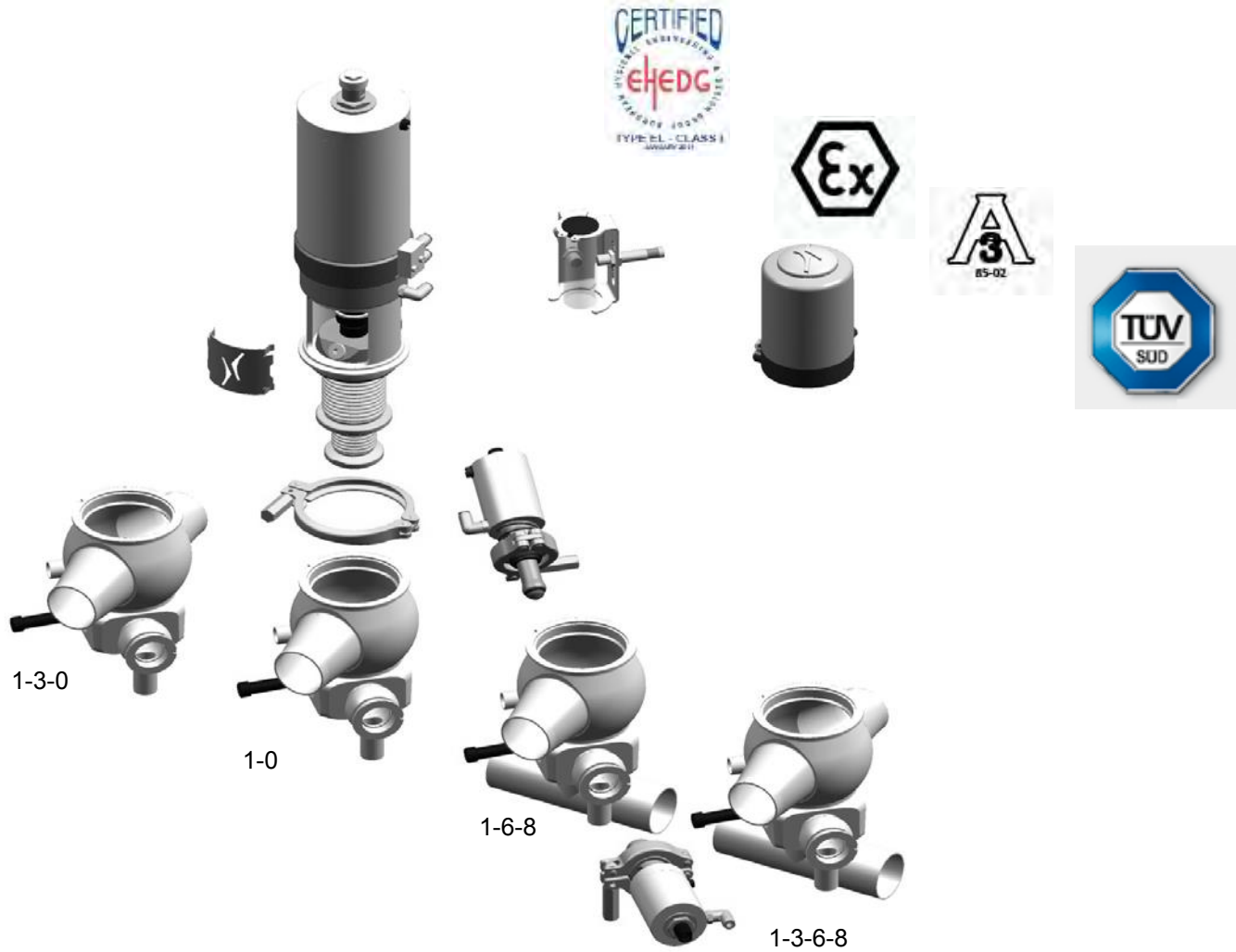

Variants



Aseptic double seat tank outlet valve

Technical details

- Actuator allocation 87 psi (6 bar); 145 psi (10 bar)
- Actuator with integrated lifting features
- Valve spindle is decoupled
- Connections:
 - Bellow monitoring
 - Leakage removal
- Housing PN 25 (360 psi)
- Free cross section
- Support for bellow
- Two-part valve disc-screwed: according to Aseptic Seat Valve
- Valve under angle



Customer benefits

- Hermetical sealing by means of the metal bellow
- No product contamination from the atmosphere
- Actuator allocation
- Free cross section according to pipe diameter
- Blocking at dismounting, guidance under vibration
- Injection of fluid against the bellow and creation of swirl in the safety chamber
- Optimised cleanability
- Process concept is available
- EHEDG certification

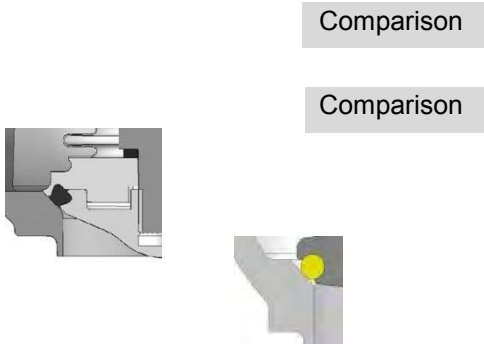
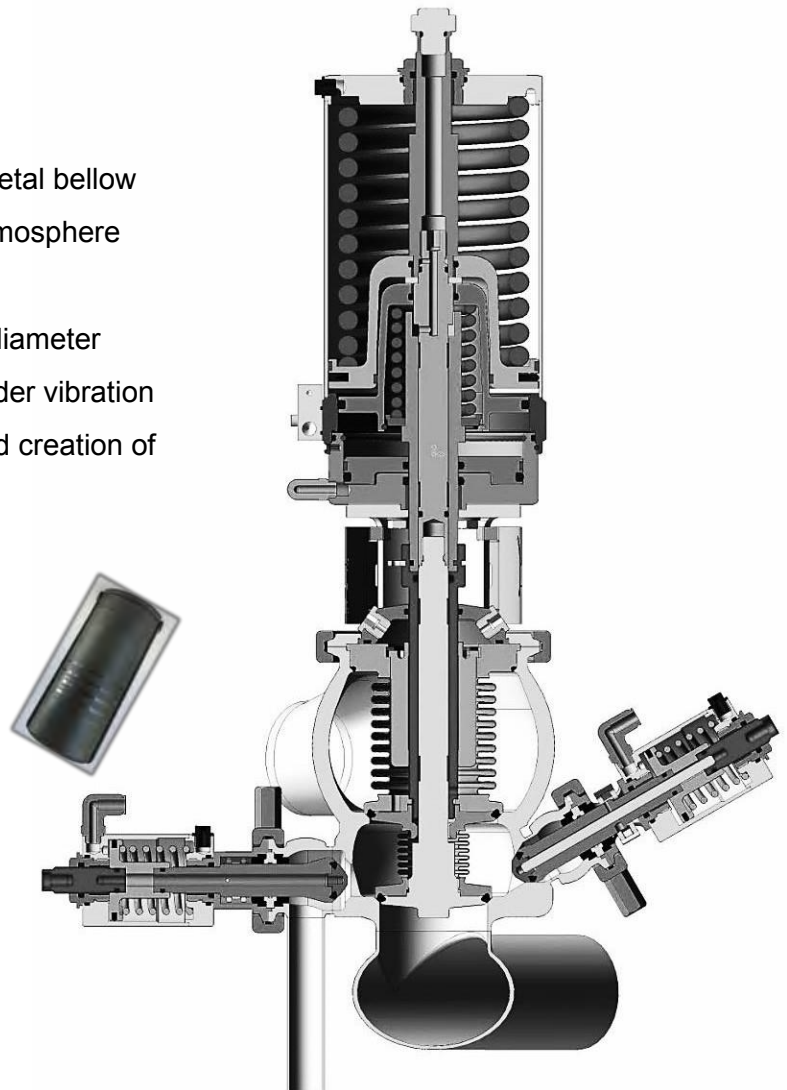

Evoguard Range Vacuum Valve

Used for protection of the tank against vacuum

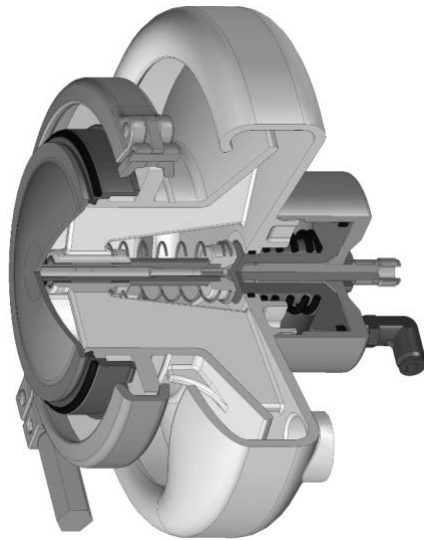

Variants

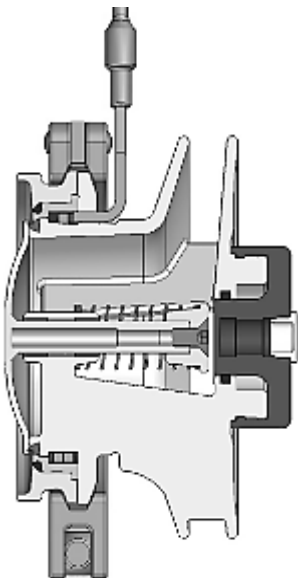

Vacuum Valve

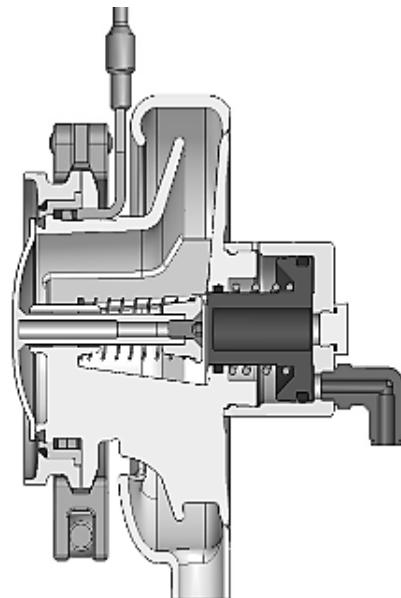

Vacuum Valve with drip cup and pneumatic actuation

Technical details

- Horizontal installation position
 - Connection welded directly to the crosspiece
- Vertical installation position
 - Connection directly to the housing
- Seal material EPDM compliant with FDA 21 CFR 177.2600 and VMQ
- Opening pressure 0.033 psi (2.3 Bar) to 0.061psi (4.2 Bar)
- Variants:
 - Not liftable, without drip cup
 - Liftable, with drip cup
- Options:
 - Heater
 - Monitoring via proximity switch

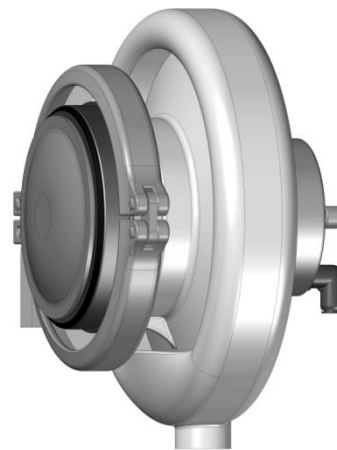

Customer benefits

- Standard connection for welding
- Optimal cleaning conditions
- No dead space
- Outlet defined over drip cup
 - Targeted discharge of fluid
 - No spraying
- Sediments from outside do not get into the tank because of horizontal installation position
- Easy assembly

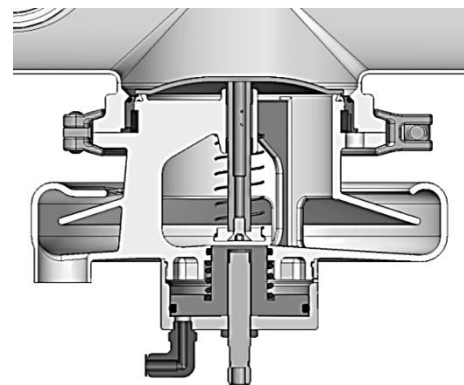
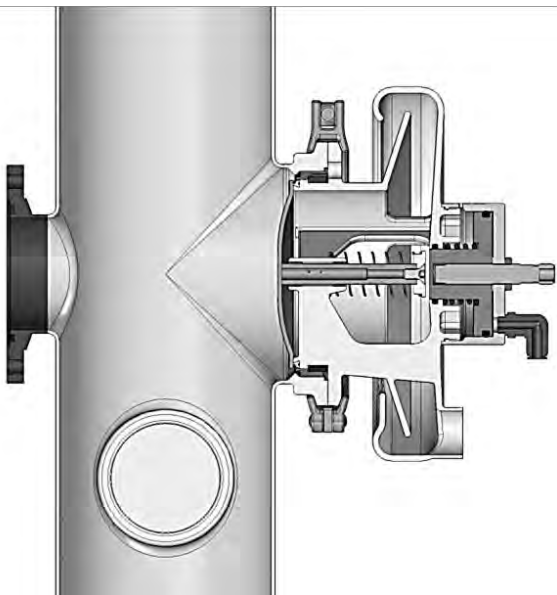

Evoguard Range Safety Valve

Used for protection of the tank against over pressure

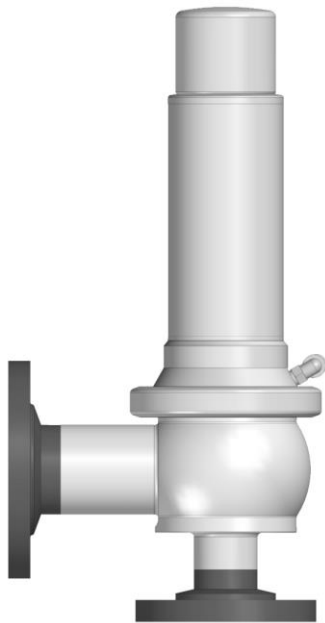

Variants

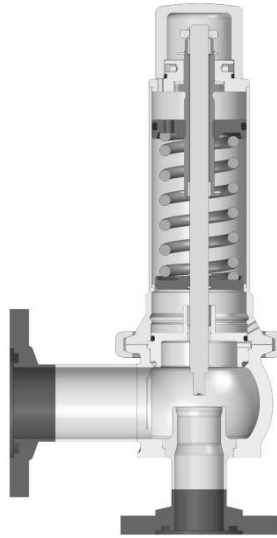

Safety Valve manual lifting device

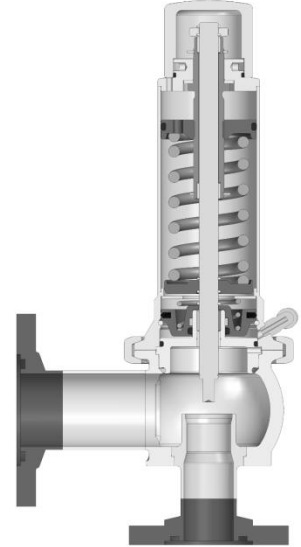

Safety Valve pneumatic lifting device

Technical details

- TÜV – Approvals
 - For steam, gases, and liquids
- Mounting horizontal / vertical
- Seal material EPDM, FDA – compliant
- Set pressure according to specification
- Variants:
 - Lifiable with manual lifting device
 - Lifiable with pneumatic lifting device
- Option:
 - Heater
 - Monitoring via proximity switch

Customer benefits

- Design and sealing systems analogues to seat valve
- Set pressure selectable
- Standard connections
- Outlet horizontal / vertical
- Easy assembly
 - Change seals in the product room without recertification from control board
- Everything from one source

Evoguard Range Control Module

Control air pressure:

Min 72 psi (5.5 bar) max 116 psi (8 bar)

Air pipe connection: Ø6 mm

Protection class: IP 67

Control: 24 VDC 3 wire PNP / NPN or AS interfere



Variant 1

- Proximity sensors
- Solenoid valves



Variant 2

- Path measurement system
- Solenoid valves
- Setting – automatic



Variant 3

- Path measurement system
- Solenoid valves
- Setting – automatic
- Control via ASI field bus



Customer benefits

- Maintenance-free
- 360 continuously adjustable
- Robust housing – combination stainless steel and plastics
- Clear detection of valve positions
- Variable equipment regarding interface and solenoid valves according to customer requirements
- Easy dismounting without disconnecting electrical and pneumatic supply lines

Evoguard Range Valve Blocks

Technical details

- Valve blocks on base frames with trays
- With switch case wiring and piping
- With control module wiring and piping
- Design according to FEM

Customer benefits

- Variable equipment regarding to customer requirements
- Safety protection by layout program
- Mounted completely and tested

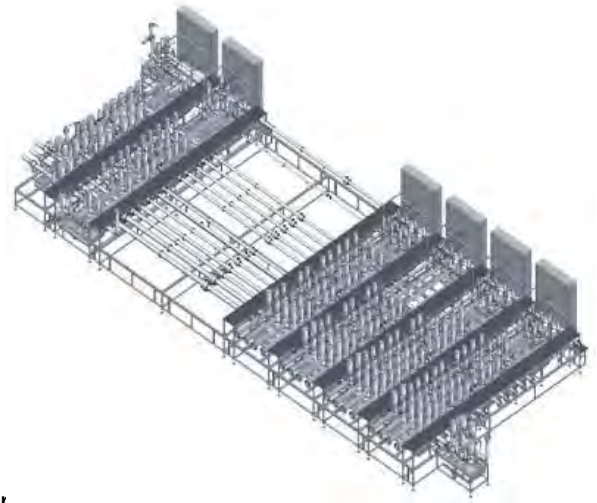

Compensator in a valve block

Technical details

- Absorption of expansion in pipe lines
- Way of compensation: 6mm
- Operating pressure: 232 psi (16 Bar)
- Seal material EPDM compliant with FDA 21 CFR 177.2600
 - Optional HNBR, FKM

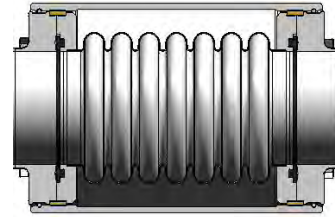

Customer benefits

- Safety protection of valve blocks
- Standard sealing
- Layout program available

stationäre Temperaturverteilung

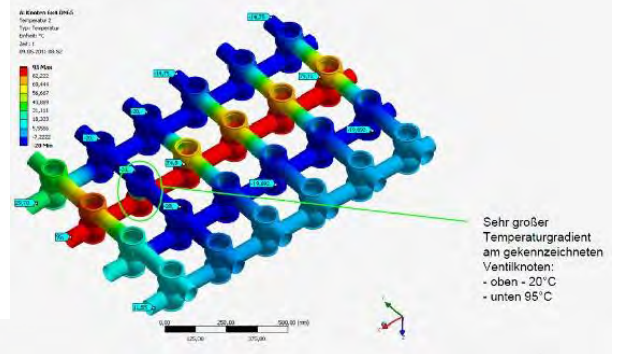

Verformung

- maximale Längenänderung entlang der warm durchströmten Rohrleitung in X-Richtung
- X-Komponente der Verformung (Gesamtmodell) + 0,58 mm bzw. - 0,56 mm

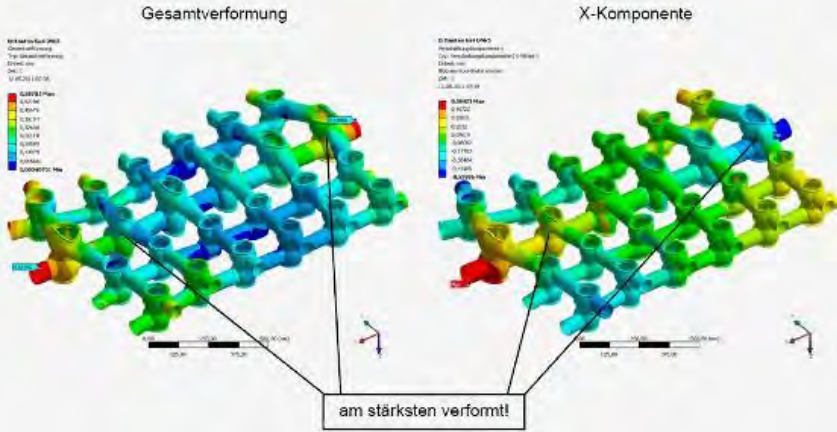

FEMFAT, Schweißnahtbewertung nach DVS 1608

Ventil 1

geringste Sicherheit gegen Dauerbruch an der umlaufenden I-Naht: 1,04
 → Schweißnaht gerade noch dauerhaft
 → keine Sicherheitsreserve

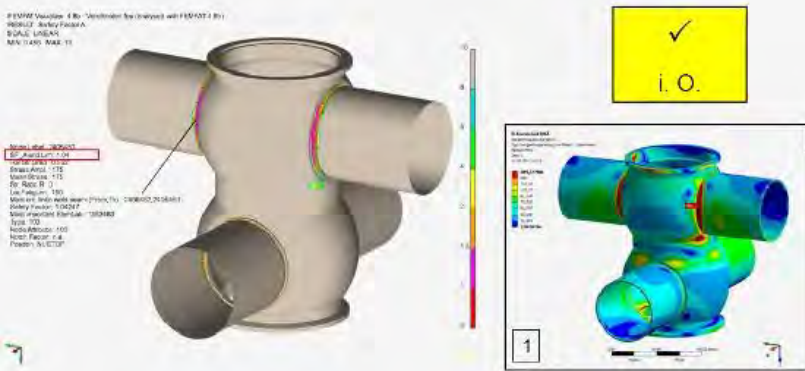

For more information visit www.hpeprocess.com

Evoguard tank safety and cleaning systems

Used for tank cleaning, protection of the tank against overpressure and vacuum and management of gas and liquid flows

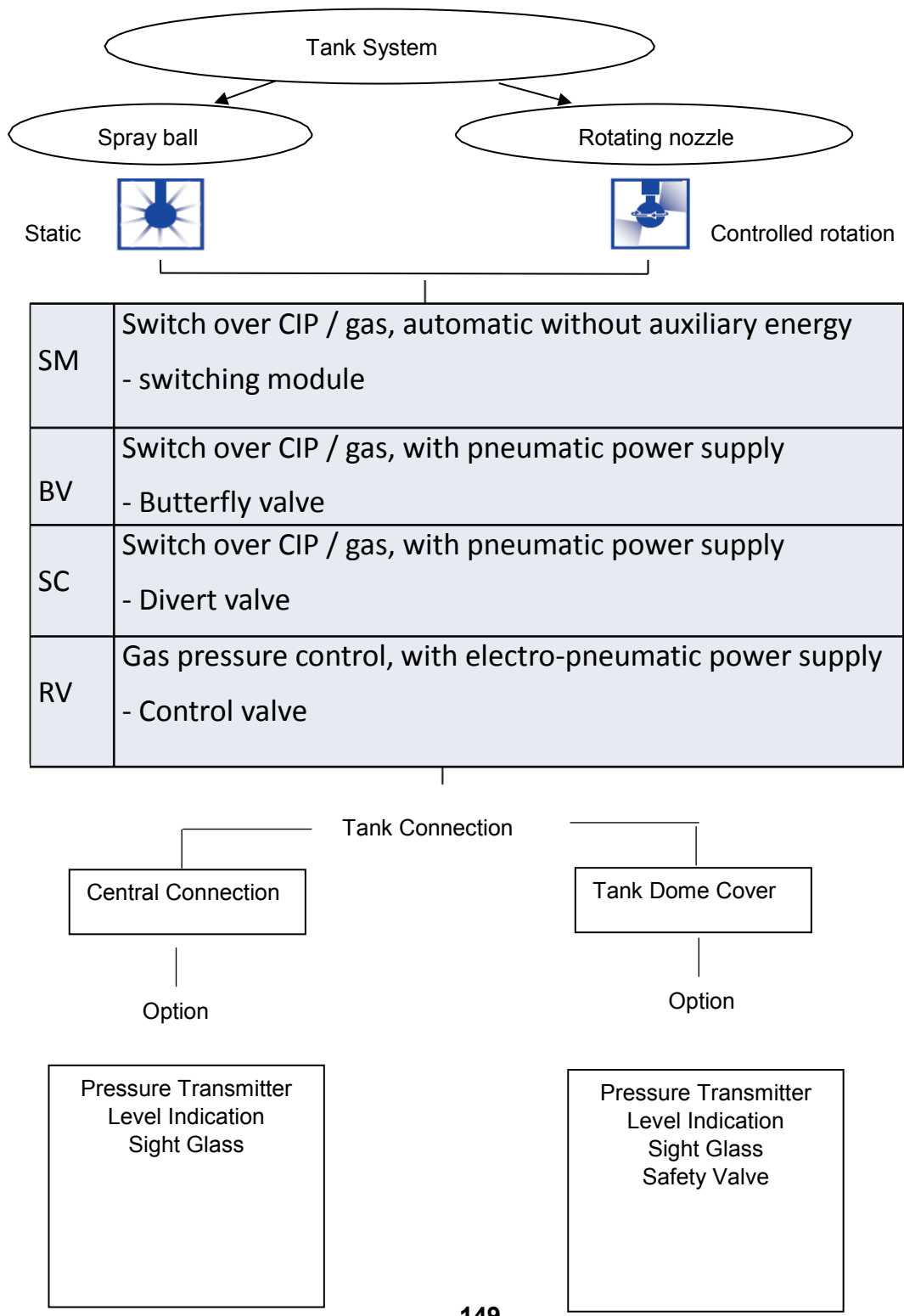



Customer benefits

- Design according to product and process requirements
- Selection according to range
- Compact unit
- Cost saving concept
- Easy assembly and disassembly

Variants of Cleaning Systems

Spray ball

Static

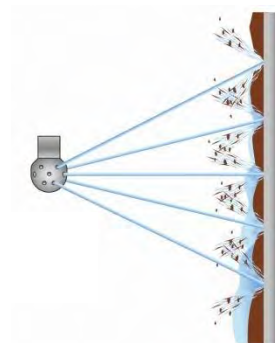

Free spinning



Rotating Nozzle

Internal regulated drive



Programmed rotation machines

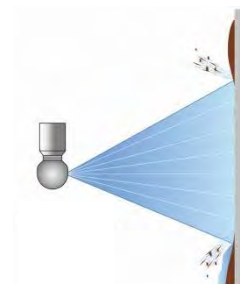

Optional: Rotation monitoring sensor

Customer benefits

- Design according to product and process requirements
- Selection according to range
- Maximum process stability
- Shorter cleaning time
- Lower process costs
- Cost saving

Variants of Tank Connections

Technical details



Central connection

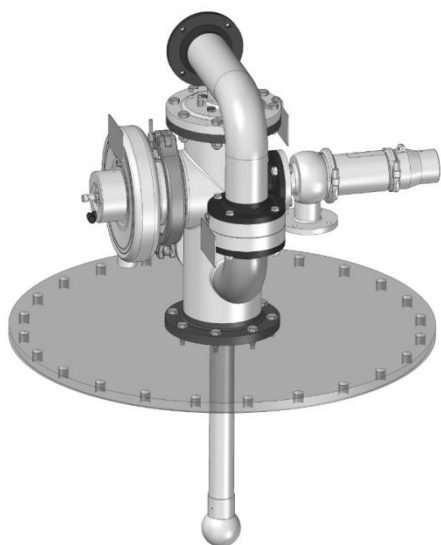

Tank Dome cover

Customer benefits

- Design according to product and process requirements
- Selection according to range
- Cost saving

Variants of Switching Modules CIP / Gas

Technical details

Switch module automatic, without auxiliary energy

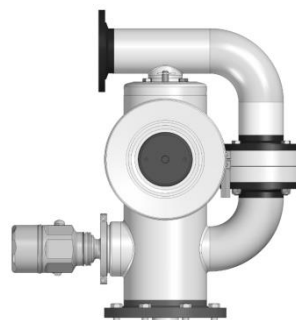

Divert valve with pneumatic power supply

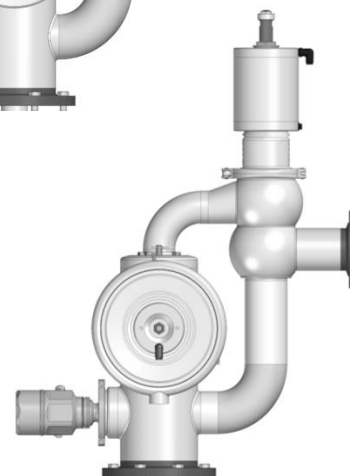

Butterfly valve with pneumatic power supply

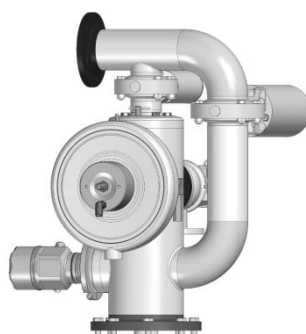

Control valve / butterfly valve with electro-pneumatic power supply

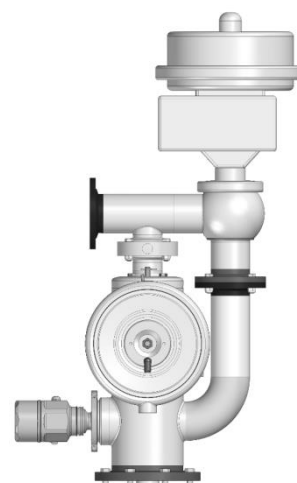

Customer benefits

- Design according to product and process requirements
- Selection according to range
- Compact unit
- Cost saving concept

Cleaning – Tank Safety Systems

Technical details

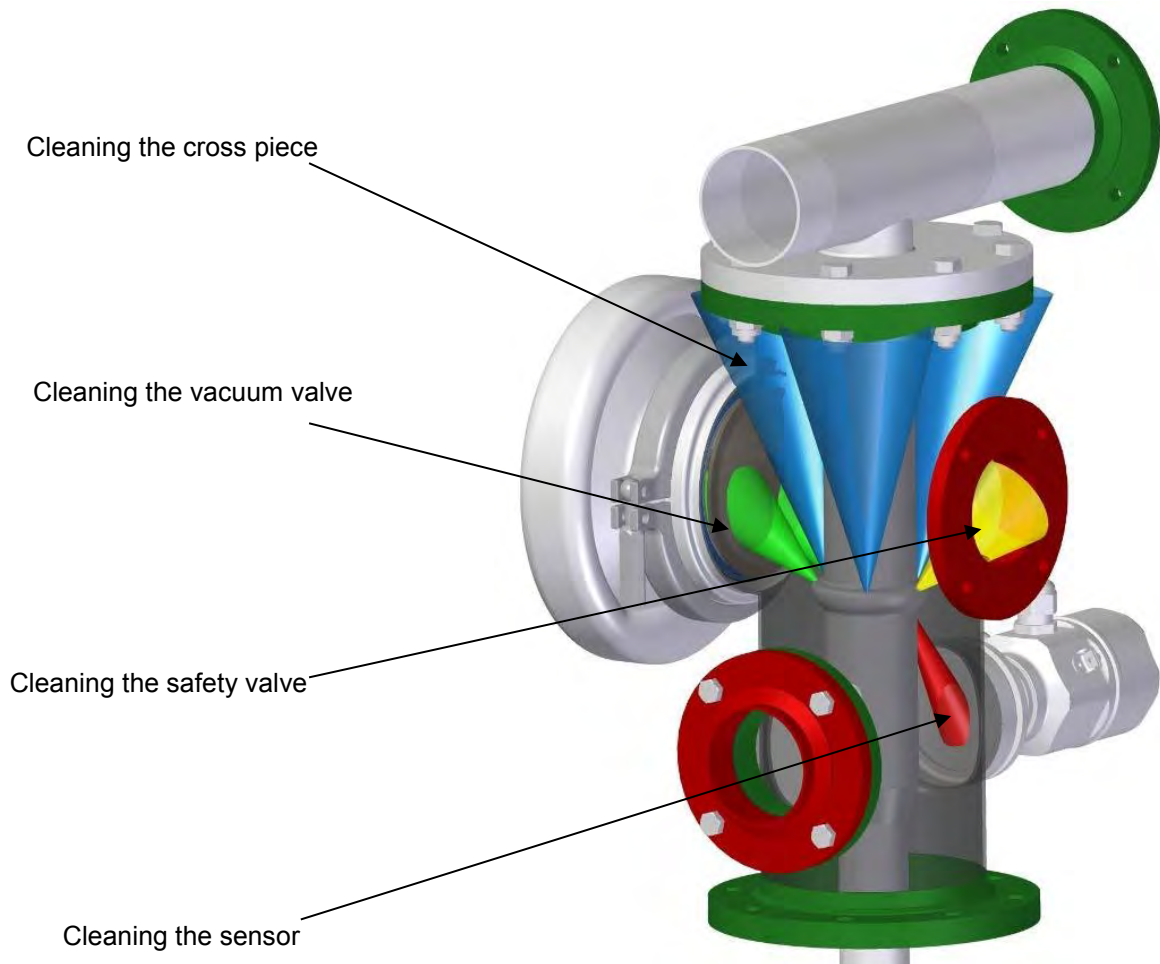

Customer benefits

- Design according to product and process requirements
- Selection according to range
- Compact unit
- Optimal cleaning conditions without extra nozzles
- Cost saving concept

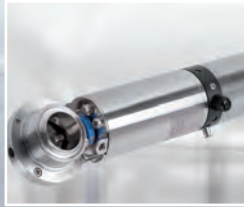

HpE Process Ltd deliver sustainable solutions to the following industries

- Adhesives
- Architectural
- Automotive
- Beverage
- Bio Chemicals
- Bio Tech
- Brewing
- Chemical
- Confectionery
- Dairy
- Food
- Household
- Paints and Coatings
- Paper
- Personal Care
- Pharmaceuticals
- Ready Meals
- Water



HpE Process Limited

Unit N2, Gildersome Spur, Leeds, West Yorkshire, LS27 7JZ

Telephone: 0113 252 6712 Fax: 0113 253 8125

email: sales@hpeprocess.com www.hpeprocess.com